



**TECHNICAL MANUAL  
FOR INSTALLATION,  
OPERATION AND  
MAINTENANCE  
OF  
THE GAYLORD "ClearAir™"  
MODEL "RSPC-TPF-PCV" SERIES  
DUCT MOUNTED POLLUTION  
CONTROL UNITS**

**WARNING**

Improper installation, adjustment, alteration, service or maintenance can cause property damage, injury or death. Read the installation, operation and maintenance instructions thoroughly before installing or servicing this equipment. Only trained and qualified service personnel should install or service this equipment.

10900 S.W. AVERY STREET • TUALATIN, OR 97062 USA  
PHONE: 503-691-2010 • TOLL FREE: 800-547-9696 • FAX: 503-692-6048  
email: [info@gaylordventilation.com](mailto:info@gaylordventilation.com) • [www.gaylordventilation.com](http://www.gaylordventilation.com)

**GAYLORD INDUSTRIES**



## GAYLORD INDUSTRIES

World Headquarters: 10900 S.W. Avery Street • Tualatin, Oregon 97062 U.S.A.

To Our Customers . .

Congratulations on your recent purchase of a Gaylord ClearAir™ Pollution Control Unit. We are proud to be able to provide you with a quality product that exemplifies our long-standing dedication to quality engineering.

Your unit is assembled from some of the very finest components available and is designed for years of efficient, effective, and trouble-free operation. In addition, this unit has undergone rigorous quality control inspections and was fully operationally tested prior to shipment.

If you have further questions, please contact us toll free at 1-800-547-9696, or [info@gaylordventilation.com](mailto:info@gaylordventilation.com). We are more than happy to help.

Sincerely,

Gaylord Industries

**STREET ADDRESS:** 10900 SW. Avery Street, Tualatin, Oregon 97062-8549 U.S.A.  
**PHONE:** 503-691-2010 • 800-547-9696 • **FAX:** 503-692-6048 • **email:** [info@gaylordventilation.com](mailto:info@gaylordventilation.com) •  
[www.gaylordventilation.com](http://www.gaylordventilation.com)

COMMERCIAL KITCHEN EXHAUST SYSTEMS • FIRE PROTECTION • UTILITY DISTRIBUTION • POLLUTION CONTROL

**TECHNICAL MANUAL  
FOR INSTALLATION,  
OPERATION AND  
MAINTENANCE**

**OF**

**THE GAYLORD “ClearAir™”  
MODEL “RSPC-TPF PCV”  
SERIES POLLUTION  
CONTROL UNIT**

Published by: GAYLORD INDUSTRIES  
Tualatin, Oregon 97062  
U.S.A.

First Printing: Feb 2018

**© Copyright 2018, Gaylord Industries**

ALL RIGHTS RESERVED. NO PART OF THIS BOOK MAY BE REPRODUCED, STORED IN A RETRIEVAL SYSTEM, OR TRANSMITTED IN ANY FORM BY AN ELECTRONIC, MECHANICAL, PHOTOCOPYING, RECORDING MEANS OR OTHERWISE WITHOUT THE WRITTEN PERMISSION OF GAYLORD INDUSTRIES. ©2018.

The manufacturer reserves the right to modify the materials and specifications resulting from a continuing program of product improvement or the availability of new materials.

Additional Copies \$25.00

GAYLORD INDUSTRIES  
10900 S.W. Avery Street, Tualatin, Oregon 97062

# TABLE OF CONTENTS

RECEIVING & INSTALLATION .....	5
HORIZONTAL INSTALLATION GUIDELINES .....	6
VERTICAL INSTALLATION GUIDELINES .....	7
SERVICE AND MAINTENANCE.....	8
REPLACING FILTERS AND MEDIA PANELS.....	9
WARRANTY.....	Inside Back Cover

## RECEIVING

Most ClearAir™ units are shipped in one piece. However, some units, because of size or special jobsite conditions, may be shipped in multiple sections. Follow the instructions that are provided with the unit to join sections back together. If the unit includes media bed odor control, the KOR48/carbon odor control media is packaged separately. Verify against the shipping documents that you have received all items and note any shipping damage, obvious or hidden, to your carrier and on your Bill of Lading. If damage is found, immediately file a claim with the transport company. All units are thoroughly inspected and fully operation tested at the factory prior to shipment.

Verify that the electrical and air flow ratings on the unit name plate agrees with jobsite requirements. If a contradiction arises notify the factory prior to proceeding with installation.

## SAFETY CONSIDERATIONS

Installing and servicing the ClearAir™ unit can be hazardous due to the presence of electrical components. Only trained and qualified service personnel should install or service this equipment.

Untrained personnel can perform basic maintenance, such as cleaning and replacing filters. All other operations should be performed by trained service personnel. When installing or servicing, observe precautions in literature and on tags and labels attached to unit.

Follow all safety codes. Wear safety glasses and work gloves. Use quenching cloth for brazing operations. Have fire extinguisher available. Read these instructions thoroughly.

---

### WARNING

Before installing or servicing system, always turn off main power to system. There may be more than one disconnect switch. *Electrical shock can cause personal injury or death.*

---

## RIGGING

All units are provided with a minimum of four (4) lifting points, or (2) continuous mounting flanges for rigging attachment. **WARNING:** Use all lifting points provided (Refer to Page 10). Spreader bars are mandatory to prevent contact and damage to the unit by lifting hooks, straps, cables, or chains. Consult the mechanical or structural engineer before moving the unit across the roof deck. Hanging weight is 375 lbs for the 1x1 and 540 lbs for the 2x1.

## INSTALLATION CODES

This unit requires external plumbing and electrical connections to be made in the field. It is recommended that the Authority Having Jurisdiction (AHJ) be consulted regarding local codes and installation procedures. Gaylord Industries is not responsible for obtaining necessary approvals and permits which may be required for installation, nor is it responsible for verifying that the unit has been installed in accordance with

national, state, and local codes. In the absence of locally adopted codes use the latest editions of the national electrical code and the uniform/International mechanical code. Connections of the exhaust duct to the inlet and outlet of the ClearAir™ unit must be fully welded to comply with NFPA-96.

## INSTALLATION PRECAUTIONS

1. The services of qualified contractors are essential for safe and proper installation of this equipment.
2. The air volumes and external static pressures that are listed on the unit are for the middle of the operating range of the filters. The initial air volume should be at least 10% higher than the listed CFM. As the filters load up the air volume will drop. This is inherent to this type of unit. If the unit is set up at or below the design CFM, as the filters load up, the kitchen hood may experience smoke loss problems. Please consult the factory if you have questions.
3. The unit is designed for installation on a level surface.
4. When installed in an enclosed space a fire-rated enclosure may be required for the unit and associated duct work. Consult the Authority Having Jurisdiction.
5. Consult the Authority Having Jurisdiction (AHJ) regarding requirements covering the point of termination of the exhaust outlet of this unit. Minimum distances must usually be maintained between the exhaust outlet and any outside air intakes and/or adjacent structures or property lines.
6. Do not apply power to the unit until all electrical connections have been made and a pre-start-up preliminary inspection has been completed.
7. Allow a minimum of 36 inches clearance in front of the filter access door and electrical compartment door for service and routine maintenance.

## SHORT TERM STORAGE

Units that include media bed odor control are provided with KOR48/carbon media which is shipped separate from the unit. KOR48/carbon media must be stored in a dry place with less than 95% relative humidity.

## LONG TERM STORAGE (OVER ONE MONTH)

Units must be covered and stored in a warm dry location to prevent excess moisture from accumulating in the odor media and final filters.

# EQUIPMENT INSTALLATION – HORIZONTAL

## HORIZONTAL MOUNTING OPTION –

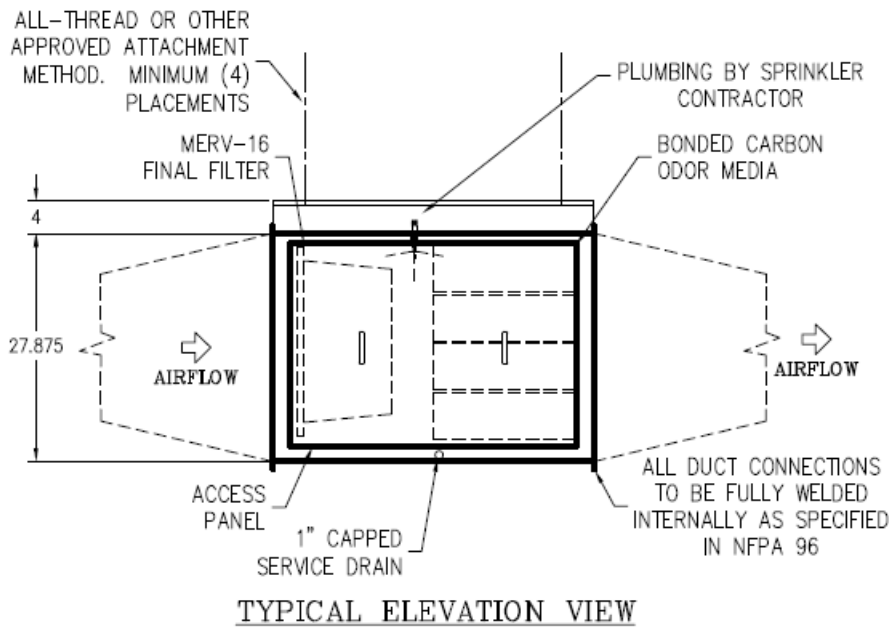
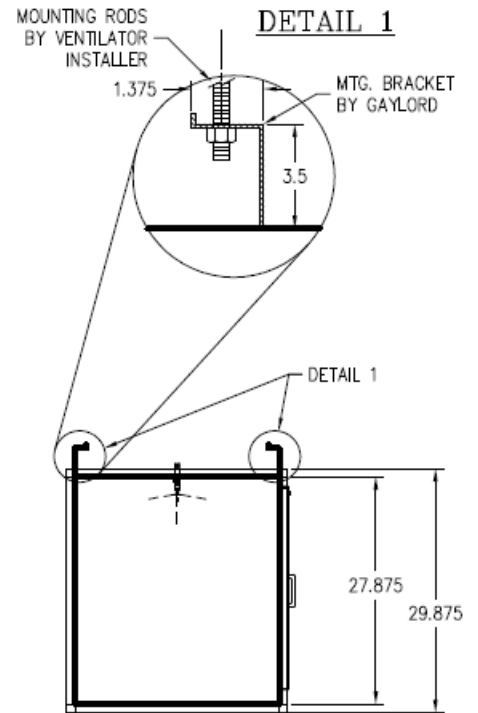
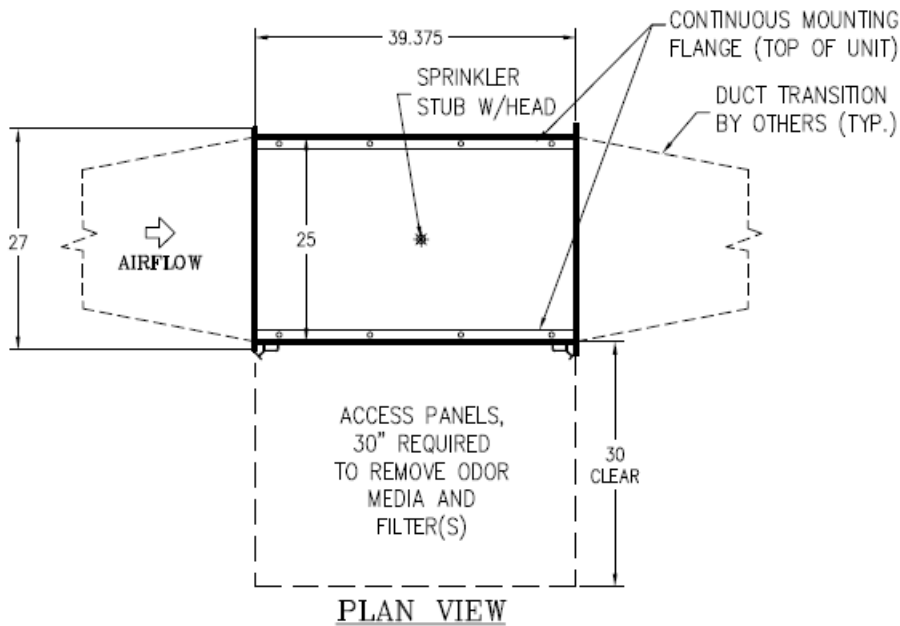

# EQUIPMENT INSTALLATION - VERTICAL

## VERTICAL MOUNTING OPTION -

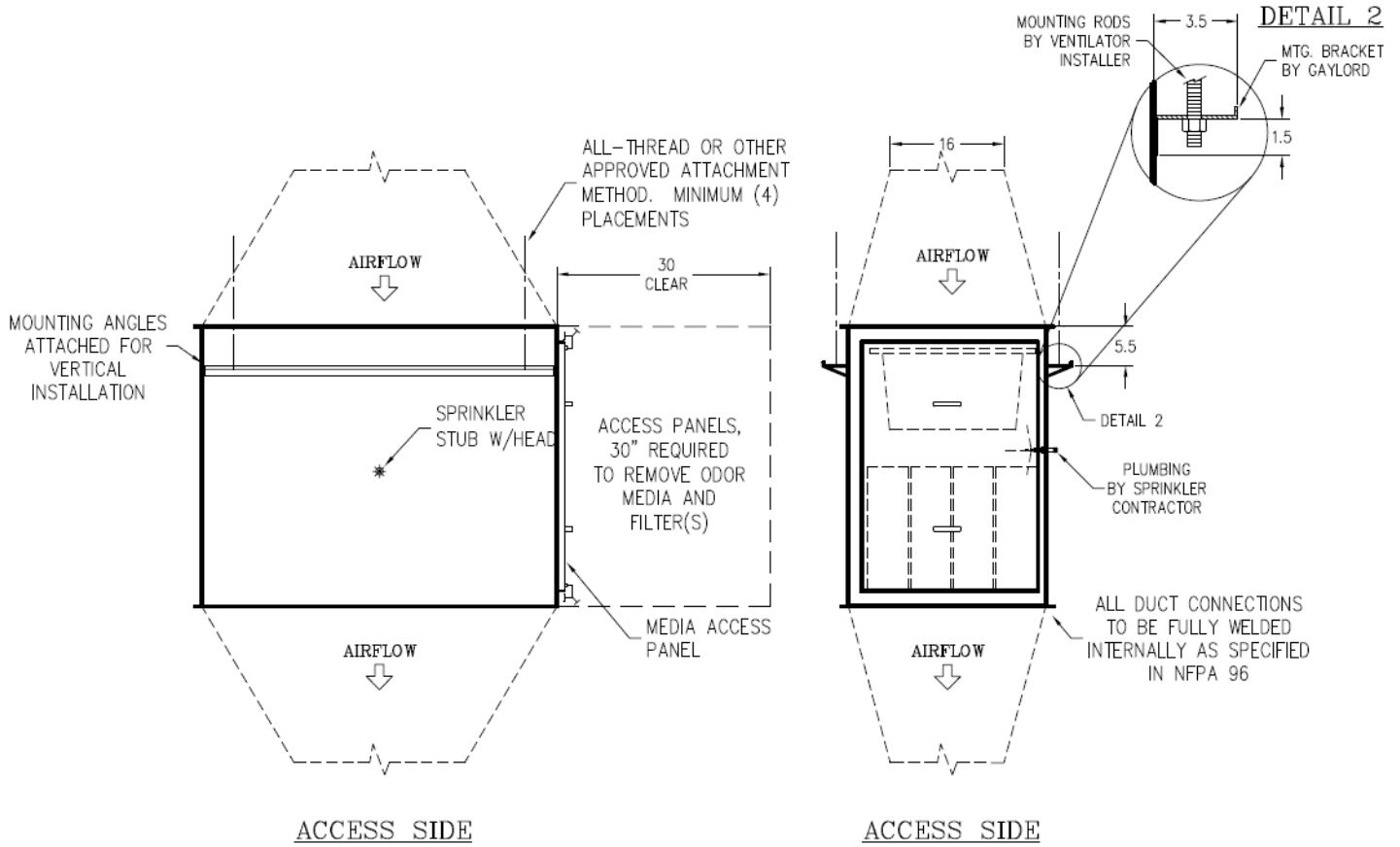

# ODOR CONTROL SECTION – MEDIA BED TYPE

## General Description

ClearAir™ units are comprised of a UL 900, MERV 16 final filter and a Potassium Permanganate/activated carbon blended module.

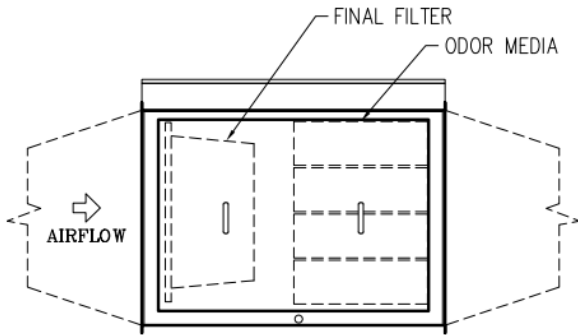

## Service and Maintenance

The Potassium Permanganate / carbon media is deep purple in color when new, turning to a dark brown during use and light tan when expended. To verify the life of the media, inspect the panels at scheduled service intervals consistent with the final filter change outs. For additional information contact Green Ladder at 630-457-1872.

## Ordering New Media Panels:

Green Ladder Technologies, LLC  
 1502 Louis Bork Drive  
 Batavia, IL 60510  
 Email: info@greenladdertech.com  
 Phone: 630-457-1872

## Gaylord Odor Control System Components

### Filters

Smoke control filters in the odor control section of the system require replacement prior to them becoming loaded. It is recommended that the filters be inspected in accordance with the “Odor Control Media Inspection Frequency Chart” on this page, and replaced when necessary. Note that failure to maintain the final filter will accelerate the degradation of the odor media, thus a regular schedule of change outs needs to be established. Replacement filters can be purchased through Gaylord Industries. Filter replacement part number: Airguard MPN VPL-0495-DOP. Filter replacements are dimensionally 24x24x12.

Symptoms of excessive filter loading will be evident from a lack of capture performance experienced at the kitchen hood(s). Systems equipped with the Gaylord AirVantage will compensate for filter loading and issue a YELLOW service alert at the AirVantage command center when the filters are ready to be replaced.

**ODOR CONTROL MEDIA INSPECTION FREQUENCY CHART**

TYPE OF COOKING EQUIPMENT	FREQUENCY IN DAYS
<b>LIGHT DUTY</b> .....	<b>120</b>
Ovens, steamers, and kettles	
<b>MEDIUM DUTY</b> .....	<b>90</b>
Braising pans/Tilting skillets, fryers, griddles, grooved griddles, open burner ranges, hot top ranges, and conveyor ovens	
<b>HEAVY DUTY</b> .....	<b>60</b>
Gas and electric char broilers, upright broilers, woks and conveyor broilers	
<b>EXTRA HEAVY DUTY</b> .....	<b>30</b>
Solid fuel broilers	

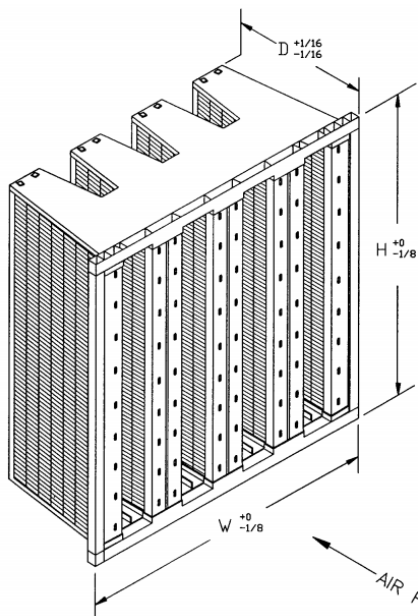



# ODOR CONTROL SECTION – MEDIA BED TYPE

## Replacing the Media and Filters

**CAUTION** - each odor module weighs approximately 28 lbs. and may be awkward to handle particularly when accessing the unit from overhead. It is highly recommended that a heavy duty steel wheeled ladder be used when removing modules when located overhead. Utilize (2) technicians where possible to safely remove and shuttle modules to an area where service can be performed.

**CAUTION** - Exhaust fan must be off before opening the odor control media access door

Replacing the media is a relatively simple task not requiring any special tools. Follow steps 1-11:

- Step 1. Deactivate the exhaust fan utilizing the C-7000 Command center, AirVantage, or wall fan switch. Locate and turn the exhaust fan disconnect to prevent the fan from turning on during service.
- Step 2. Provide safe sturdy access to the odor control module.
- Step 3. Pull tee-handles on each side of the access cover. Remove access cover and securely set aside. Inspect access panel gaskets and replace as necessary. **CAUTION:** Store access cover in a location where it will not be susceptible to damage or falling onto staff or other equipment.
- Step 4. Remove and Inspect final filter. Note filter(s) slide in and out of the unit through a rack. Replace as necessary. Replacement is required when: 1) Back side of filter is contaminated 2) AirVantage Yellow Alert is present at the Command Center 3) hood(s) starts to perform poorly, (*Smoke Loss*)
- Step 5. **Odor Media Panels:** Carefully slide the panels out of the unit.
- Step 6. Lift the locking clip as shown below.

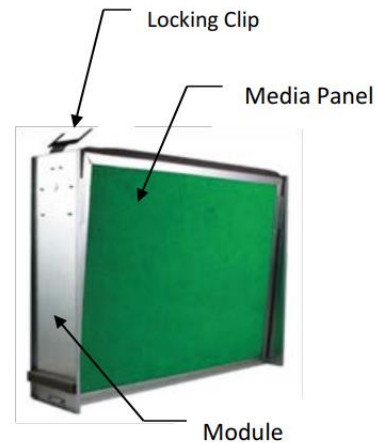
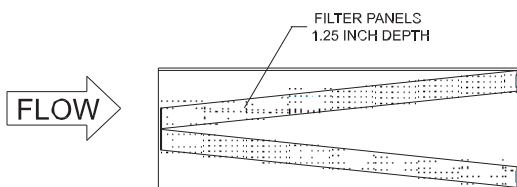

Step 7. Lift out both Media Panels as shown below.



- Step 8. Slide in the new Media Panels making sure the label stating "Inlet Side" is facing out. The two stiffening rods on the back of the panel should be facing the inside of the "V". Note the foam seal will be on the top side of the V.
- Step 9. Place the Media Panels back in the unit with the sharp end of the "V" as shown below.
- Step 10. Confirm all filters and media panels are in place. Replace odor media access panel. Secure in place with the tee-handles. Confirm a good seal has been established.
- Step 11. Dispose of the used Media Panels.

## LIMITED WARRANTY

### THE GAYLORD ClearAir™ POLLUTION CONTROL UNIT

#### LIMITED WARRANTY

The Gaylord ClearAir™ Pollution Control Unit is warranted by GAYLORD INDUSTRIES to be free from defects of material and workmanship under normal use when installed, operated and serviced in accordance with factory recommendations.

GAYLORD INDUSTRIES' obligation under this warranty shall be limited to repairing or replacing at its option any part of said equipment which GAYLORD INDUSTRIES examination shall disclose to its satisfaction to be thus defective, for a period of one (1) year from the date of installation provided proper and acceptable evidence of such installation is recorded at the factory or 18 months from date of shipment which - ever occurs first.

**GAYLORD INDUSTRIES SHALL NOT BE RESPONSIBLE FOR INCIDENTAL OR CONSEQUENTIAL DAMAGES RESULTING FROM A BREACH OF THIS WARRANTY.**

All replacement parts furnished under this warranty shall be F.O.B. Gaylord Industries of Tualatin, Oregon. The owner shall pay the necessary freight delivery charges, and necessary labor for removal and installation of parts, and any federal, state or local taxes.

#### **SPECIFIC ITEMS NOT COVERED BY THIS WARRANTY:**

1. Fan belts if equipped with an exhaust fan.
2. Pre-filters, bag filters, final filters, after filters, and KOR48/carbon media if equipped with odor control.
3. Routine maintenance and cleaning as spelled out in The Gaylord ClearAir™ Model OCU-FF Series Unit Technical Manual.
4. Malfunction or improper operation caused by fluctuating electrical or power surges or improper installation.

This is the sole warranty with respect to the aforesaid items. NEITHER GAYLORD INDUSTRIES OR ANY OTHER PARTY MAKES ANY OTHER WARRANTY OF ANY KIND WHATSOEVER, EXPRESSED OR IMPLIED, AND ALL IMPLIED WARRANTIES OF MERCHANTABILITY AND FITNESS FOR A PARTICULAR PURPOSE WHICH EXCEED THE AFORESAID OBLIGATIONS ARE HEREBY DISCLAIMED AND EXCLUDED FROM THIS AGREEMENT.

This Page Intentionally Left Blank



**WORLDWIDE SALES, MANUFACTURING AND SERVICE  
FOR THE NAME AND LOCATION OF THE NEAREST  
CERTIFIED SERVICE AGENCY, VISIT OUR WEB SITE:**

**[WWW.GAYLORDVENTILATION.COM](http://WWW.GAYLORDVENTILATION.COM)**

OR CONTACT US AT:

**GAYLORD INDUSTRIES**

10900 SW AVERY STREET  
TUALATIN, OREGON 97062 U.S.A

**Phone:** 503-691-2010

1-800-547-9696

**Fax:** 503-692-6048

**email:** [info@gaylordventilation.com](mailto:info@gaylordventilation.com)

LOCAL SERVICE AGENCY