

MODEL "RSPC-TPF"

POLLUTION CONTROL UNIT

GENERAL SPECIFICATIONS AND DESCRIPTION

GENERAL: Furnish one (1) Gaylord ClearAir™ Pollution Control Unit model RSPC-TPF series as manufactured by Gaylord Industries in accordance with the following:

The pollution control unit shall consist of a smoke control section, odor control section (optional) and an exhaust fan section (optional) all built on a common base as an integral unit. Smoke control shall be accomplished by a three stage high-efficiency filter section (TPF). The unit shall be ETL listed and labeled.

SMOKE CONTROL SECTION: The smoke control section shall have three phases of filters. The filters shall consist of replaceable 30% pre-filter, 95% bag filter and a replaceable 95% DOP final filter. Replaceable filters shall be mounted in filter slide tracks to prevent air bypass around the ends of the installed filter bank. Filters shall be accessed through removable side access panels with lift and turn latches. A thermostat, set at 250°F, shall also be located in the filter section to shut down the exhaust fan in the event of a fire.

Phase one filters shall have an average efficiency of 25% to 30% and an average arrestance of 90% to 92% in accordance with ASHRAE test standard 52.1-1992. Media support grid shall be on 1" centers with an open area 96%. Filter enclosing frame shall be a rigid, high wet strength beverage board with diagonal support members 4" deep.

Phase two filters shall have an average efficiency of 90% to 95% in accordance with ASHRAE test standard 52.1-1992. Sealing surface and pocket retainers shall be configured to provide 84% open area. Seams in bag filters shall be sealed with foamseal adhesive to completely eliminate air leakage through stitch holes.

Phase three filters shall be 95% efficient on 0.3 micron particles (DOP smoke test), 97% efficient on nebulized staphylococcus aerosols, 99+% efficient on atmospheric test dust (ASHRAE standard 52.1-92). The casing shall be 16-gauge steel with corrugated aluminum separators to ensure media stability. Media shall be fine-fiber, high strength micro-fiberglass paper. Media end cuts shall be encapsulated in urethane potting adhesive. *Optional Fire Damper for use in Canada: The unit shall include a UL listed fire damper, with a 280°F fusible link, located downstream of the filters to prevent passage of fire to the duct downstream of the unit.*

FILTER MONITORING PANEL (FM-1000): A monitor panel, for remote location, shall be supplied for the operation and monitoring of the unit. The panel shall be constructed of 18-gauge stainless steel, number 4 finish, and be suitable for surface or recessed mounting. The panel face shall be a hinged door with a lift and turn flush latch. The panel shall include an air proving time delay, and a PLC with display screen to continuously monitor the unit. The display shall indicate "Fan On", "Normal Air", "Low Air", "Replace Pre-Filters", "Replace Bag Filters", "Replace Final Filter", "Missing Filter", and "Fire In Unit". The display screen capable of indicating an alarm status, shall be included and shall activate whenever the unit status is low air, replace filters, missing filters or fire in the unit. Status other than "Fire In Unit" shall not shut down the exhaust fan.

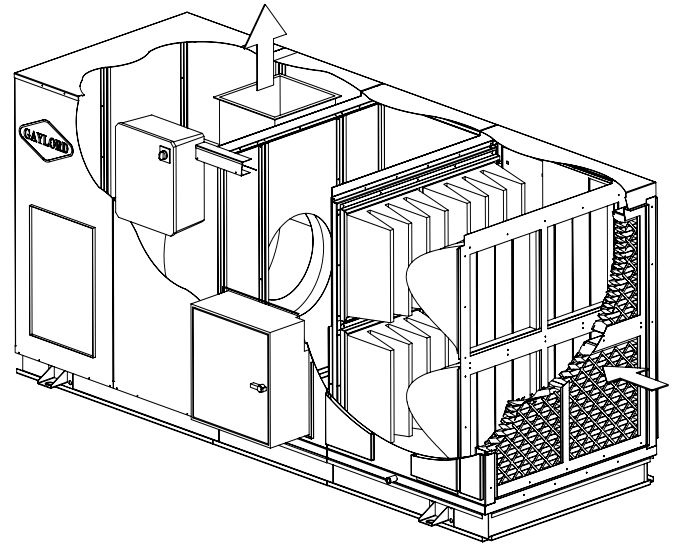

APPLICATION

Specifically designed for use with high-efficiency water wash or cartridge ventilators for the removal of smoke and odor from the airstream of commercial kitchen exhaust systems.

FEATURES

- Utilizes three stage high-efficiency filter sections (TPF)
- Pre-engineered for efficient and cost-effective smoke and odor control
- Custom designed up to 32,000 CFM
- Includes Filter Monitoring Station (FM-1000)
- One year parts warranty

OPTIONS

- Sprinkler or liquid chemical internal fire protection available
- Optional Centrifugal or Tubular exhaust fan
- Media bed control available
- Wet chemical or water spray fire extinguishing systems
- Optional variable speed control available

Specifier Note: If the ClearAir™ unit is used in conjunction with a water wash ventilator, the monitor panel is built into the main water wash control cabinet model GPC-7000 series.

ODOR CONTROL OPTIONS:

Media Bed of 50/50 Blend Potassium Permanganate & Carbon Blend - The unit shall be provided with odor control utilizing a media bed of 50% potassium permanganate/50% carbon blend complying with UL 900 Type 1 classification. The odor removal media shall be housed in slide out reusable steel modules. There shall be a rack to accept 30% pleated media after filter located immediately downstream of the odor control media. Optional replaceable filters shall be mounted in filter slide tracks to prevent air bypass around the ends of the installed filter bank. The odor control media and after filters shall be removable through side access doors with lift and turn latches.



Intertek

GAYLORD INDUSTRIES

10900 SW AVERY ST • TUALATIN, OREGON 97062 U.S.A.
PHONE: 800.547.9696 • FAX: 503.692.6048 • email: info@gaylordventilation.com
www.gaylordventilation.com

EXHAUST FAN OPTIONS:

Exhaust Fan (Standard Centrifugal Fan)

The unit shall include a centrifugal exhaust fan listed to UL 762. The exhaust fan shall be an SWSI upblast arrangement #9 with a non-overloading BI, AF or FB wheel. The motor, drives, bearings and fan mounting base shall be located out of the exhaust air stream as required by the International Mechanical Code and NFPA-96. The fan shall be AMCA certified and bear the AMCA seal for performance. The fan housing shall be constructed of heavy gauge steel. The fan bearings shall be heavy-duty self-aligning pillow block type rigidly mounted on heavy structural steel supports. The motor shall be PE, inverter-ready ODP three-phase mounted on a common base with the fan and shall be pre-wired to the electrical cabinet located on the unit. The electrical cabinet shall include a disconnect switch, motor starter, overloads and fuses. The factory provided drive assembly shall be adjustable pitch on 5 HP and smaller, fixed pitch on 7.5 HP and larger. It shall also be sized for a minimum 1.5 service factor. After final system balancing, fixed pitch sheaves shall be provided and installed by the air balancing contractor to provide proper flow at actual installed conditions.

Exhaust Fan (Optional Tubular Fan)

The unit shall include a tubular centrifugal exhaust fan. The motor, drives, bearings and fan mounting base shall be located out of the exhaust air stream as required by the International Mechanical Code and NFPA-96. The fan shall be AMCA certified and bear the AMCA seal for performance. The fan housing shall be constructed of heavy gauge steel. The fan bearings shall be heavy-duty rigidly mounted on heavy structural steel supports. The motor shall be PE, inverter-ready ODP three-phase mounted on a common base with the fan and shall be pre-wired to the electrical cabinet located on the unit. The electrical cabinet shall include a disconnect switch, motor starter, overloads and fuses. The factory provided drive assembly shall be adjustable pitch on 5 HP and smaller and fixed pitch on 7.5 HP and larger. It shall also be sized for a minimum 1.5 service factor. After final system balancing, fixed pitch sheaves shall be provided and installed by the air balancing contractor to provide proper flow at actual installed conditions.

EXHAUST FAN HOUSING: The exhaust fan section of the unit shall be enclosed with the same material as the smoke control section. There shall be a hinged panel for access to the fan.

UNIT CONSTRUCTION: The unit housing shall be constructed of a minimum 16-gauge G90 bright galvanized steel. The perimeter base shall be 12-gauge formed channel with lifting lugs at each corner and along the length as required. The internal housing shall be externally welded liquid tight for compliance to the International Mechanical Code and NFPA-96 grease duct construction requirements.

FIRE EXTINGUISHING SYSTEM OPTIONS:

Specifier Note: NFPA-96 requires a fire extinguishing system for protection of the smoke and odor control sections and protection of the duct downstream of any filters or dampers. Not all authorities having jurisdiction require protection. Check with your AHJ. If required, specify one of the following systems.

WET CHEMICAL SYSTEM: Provide a complete factory mounted Ansul wet chemical fire extinguishing system, including nozzles piping and detection runs. Pipe penetrating the unit cabinet shall use a UL listed fitting. System shall be installed in accordance with the systems listing and NFPA-96. The Ansul Automan cabinet shall be mounted on the side of the unit for easy access, certification and service if space allows. If there is not space for the FP cabinet it will be shipped loose and be mounted in the field by the FP installer. If the unit is exposed to freezing conditions, the Ansul Automan cabinet shall be mounted in an insulated thermostatically controlled heated cabinet.

WATER SPRAY SPRINKLER FIRE SYSTEM:

Specifier Note: Units that are located indoors may be factory pre-piped for a wet pipe building sprinkler system.

Provide a pre-piped water spray fire system installed in accordance with NFPA-96. The unit shall be piped with one pendent type sprinkler nozzle located in the smoke control section, one in the odor control section, if equipped with 50/50 media bed, and one in the exhaust fan section for interconnection to the building sprinkler system by the appropriate trades. Pipe penetrating the unit cabinet shall use a UL listed fitting. Nozzles shall be the bulb type rated at 325°F.

CHECK OUT AND DEMONSTRATION:

Upon completion of installation, the entire pollution control system, including the kitchen exhaust hoods, shall be commissioned by a factory certified service technician. Start-up shall include checking all filters, filter monitoring station, odor control and exhaust fan. The appropriate maintenance personnel shall be given a technical manual and a complete demonstration of the system, including operation and maintenance procedures. Upon completion of the commissioning, a detailed start-up report shall be made available to the architect and owner certifying proper system operation. Changes required in fan drive components shall be performed by the air balancing contractor per instruction of the Gaylord start-up representative.

The manufacturer reserves the right to modify the materials and specifications resulting from a continuing program of product improvement or the availability of new materials.