

MODEL "ELX-BB"

HIGH EFFICIENCY EXTRACTOR VENTILATOR

GENERAL SPECIFICATIONS AND DESCRIPTION

Furnish Gaylord Ventilator Model "ELX-BB-_____" as shown on plans and in accordance with the following specifications:

HIGH EFFICIENCY EXTRACTION: Each ventilator shall contain "XGS" High Efficiency Extractors utilizing the "capture and drain" principle. Extractor efficiencies shall be determined using ASTM F2519-2005 testing procedures as accepted by ASHRAE TC 5.10 and ASHRAE Standard 154-2011 - 4.7.2. The High Efficiency Extractors shall not exceed 55 db, on typical cooking lines, as measured at the chef's ear so fatigue is minimized and productivity is optimized.

HOOD CONTROLS: Ventilator incorporates canopy mounted RTD's positioned strategically across the length of the hood to produce a contact closure to react to cooking activity to comply with IMC.

CAPTURE AND CONTAINMENT: Each ventilator shall achieve capture and containment using the lowest possible airflow rates through "passive" versus "active" design features, thus eliminating the wiring or adjustment of internal motors, plenums or jets. The lowest possible airflow rates shall be tested to ASTM 1704-09 by the Food Service Technology Center and published on their website for easy confirmation.

<http://www.fishnick.com/publications/appliancereports/hoods/>

CONSTRUCTION: The ventilator shall be of all stainless steel construction, not less than 18 gauge, type 300 series. All exposed surfaces shall be a number 4 finish. The use of aluminized steel or galvanized steel is not acceptable. The ventilator shall be configured with two separate exhaust plenums. The ventilator shall include a static pressure port in each section to be used in balancing exhaust air volumes. Continuous front and rear mounting brackets shall be provided to facilitate mounting to the wall and hanging from the overhead building structure. Each duct collar shall include as standard a Gaylord Balancing Damper (GBD) with opposed blades that adjust manually through access from within the canopy. Ventilators built in end-to-end multiple sections shall have as standard "Continuous Capture" from one end to the other to ease cleaning and improve capture and containment.

LIGHT FIXTURES: The ventilator shall be equipped with:

- Recessed LED 6 Watts/Ft. Min.
- Recessed fluorescent 12 Watts/Ft. Min.
- 100 watt surface mounted incandescent 24 Watts/Ft. Min.
- 150 watt recessed incandescent 36 Watts/Ft. Min.

Light fixtures shall be factory pre-wired to a single connection point. Ventilators built in multiple sections shall be furnished with coiled flex conduit for interconnecting sections.

ACCEPTANCE & APPROVALS: Each ventilator shall include an integral listed Demand Control Autostart fan equipment interlock complying with IMC (optional outside North America). Each ventilator shall be Listed to UL Standard 710, ULC S646 and NSF/ANSI 2, comply with all requirements of NFPA-96, IMC, UMC, BOCA, and SBCCI standards and be capture tested to ASTM 1704-09 with XGS High Efficiency Extractors tested to ASTM 2519-2005.

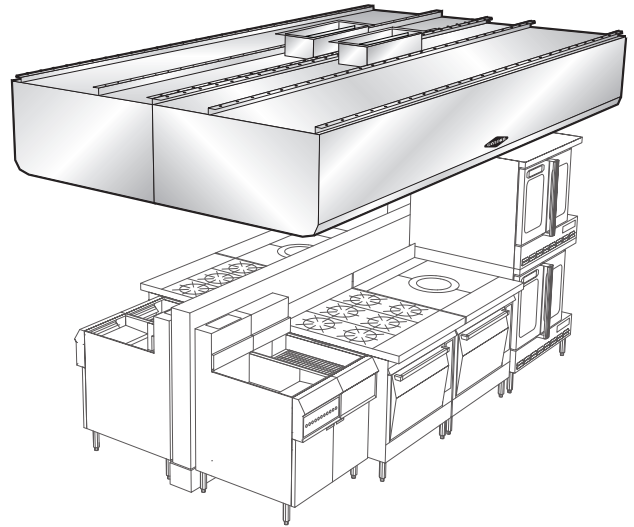
**APPLICATION**

Island style for all double island arrangements

DESIGN FEATURES

- Demand Control Autostart
- Internal Canopy Radius
- Enhanced "XGS" Extractor Angle and Slot Spacing
- Faceted "Super Capture"™ Lip

OPTIONAL EQUIPMENT

1. Decorative Facings and Trim
2. Demand Control Ventilation
3. Fire Extinguishing Systems
4. Pollution Control Systems
5. Utility Distribution Systems
6. "XGS" Spark Arrestor Extractors

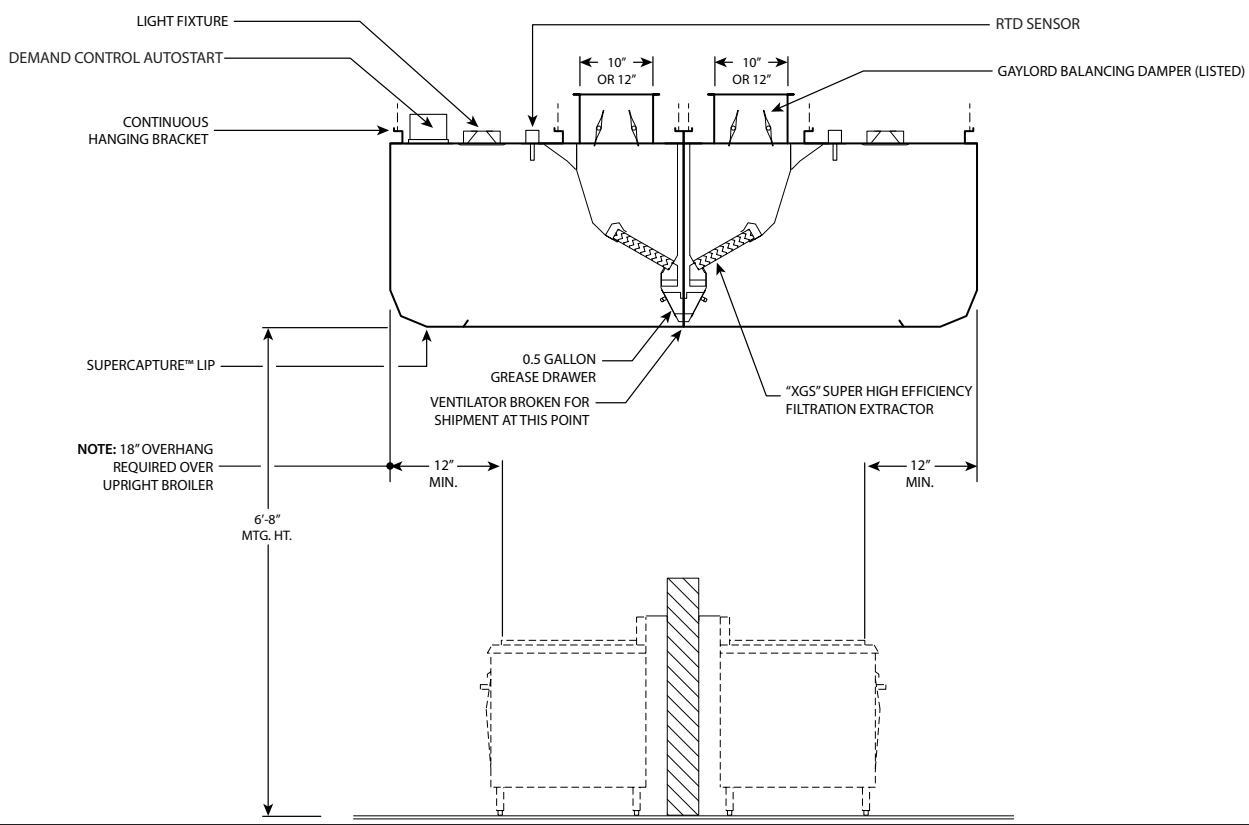
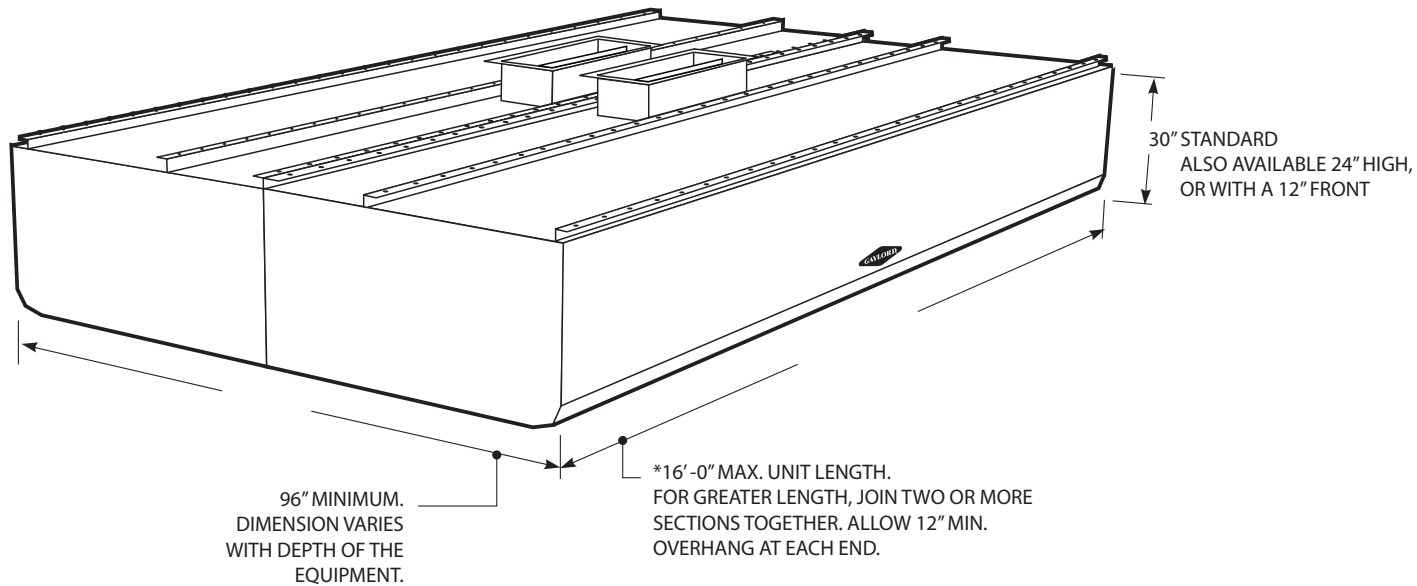

ENGINEERING DATA

Mechanical Requirements

The amount of exhaust volume required is dependent upon the type of cooking equipment and the type and volume of cooking. Contact factory for exhaust volumes, duct sizes, and static pressures.

Electrical

A Gaylord stop/start switch, Model C-150, may be provided as an option for each exhaust fan. Lights to be on separate circuit, 120 volt standard, 220/240 volt optional.

Ventilator Lengths

Maximum unit length 16'-0". For greater lengths, join two or more sections together. Check to ensure that there is adequate access into building and kitchen area.

*Note: Ventilators manufactured outside North America; maximum unit length 10'-0".

Hanging Weight

Ventilator Width	96"	108"	120"	132"
Wt. / Lineal Ft.	Lbs. 140	150	160	170

The manufacturer reserves the right to modify the materials and specifications resulting from a continuing program of product improvement or the availability of new materials