

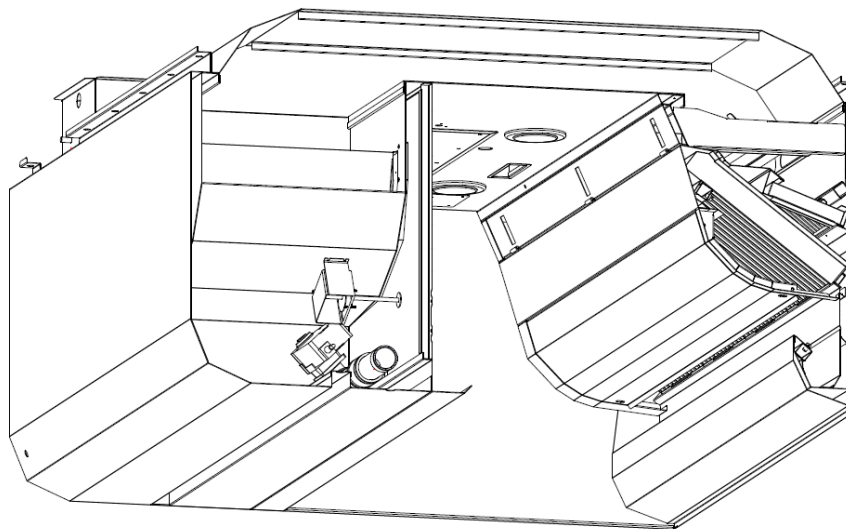

Breathe easy.



OPERATION, MAINTENANCE & INSTALLATION
of
ELXC-SPC Series Commercial Kitchen
Smoke & Odor Abatement Ventilators

GAYLORD INDUSTRIES

10900 SW Avery Street – Tualatin, Oregon 97062 USA

Email: info@gaylordventilation.com Toll Free 800.547.9696 Fax 503.692.6048

www.gaylordventilation.com

No part of this book may be reproduced, stored in a retrieval system, or transmitted in any form by an electronic, mechanical, photocopying, recording means or otherwise without prior written permission of Gaylord Industries.

©2020 - Gaylord Industries

The manufacturer reserves the right to modify the materials and specifications resulting from a continuing program of product improvement or the availability of new materials.

Table of Contents

Chapter 1 – Introduction

Introduction.....	1-1
Functions and Features of the ELXC-SPC hood	1-2
Model Number Sequence and Explanation	1-3
Eliminator System Diagram.....	1-5

Chapter 2 – Principles of Operation – *ELXC-SPC & GPC-7000-SPC Command Center*

Starting the Exhaust Fan – Manual Operation.....	2-1
Stopping the Exhaust Fan – Manual Operation	2-2
Wash Cycle Overview and Sequence	2-3
Fire Protection System	2-8
UV System Overview	2-9
PCU (Pollution Control Unit) ESP Monitoring	2-11
Opacity Sensor Overview	2-13
Odor Abatement System Overview	2-14

Chapter 3 – Preventative Maintenance

Operator Preventative Maintenance Overview.....	3-1
Scheduled Preventative Maintenance	3-2
Exhaust System Inspection Schedule	3-3
ESP Cell and Crossover Duct System Maintenance.....	3-7
Reinstallation of ESP Cell.....	3-9
ESP Cell Hoist Procedure	3-10

Chapter 4 – Settings and Adjustments

Operator Settings and Adjustments Overview	4-1
ELXC-SPC Scheduled Wash Times Table.....	4-2
Water Consumption Chart – ELXC Series.....	4-3
ELXC-SPC Odor Catalyst Settings.....	4-4
Name Plate – ELXC Series Ventilator.....	4-5
ELXC-SPC Recommended Detergent.....	4-6
ELXC-SPC Recommended Odor Catalyst	4-8
ELXC-SPC Cell Adjustments	4-9
Setting the EMX Opacity Sensor.....	4-10
EMX Opacity Sensor - AirVantage Programming	4-11

Chapter 5 – Troubleshooting

Troubleshooting – Smoke Loss.....	5-1
Troubleshooting – Exhaust Fan.....	5-2
Troubleshooting – Wash System.....	5-3
Troubleshooting – Plenum and Extractor Wash	5-4
Troubleshooting – Drains.....	5-6
Troubleshooting – UV System.....	5-7
Troubleshooting – ESP (Smoke Removal)	5-10
Troubleshooting – ESP (Smoke Removal/Odor Abatement)	5-11

Table of Contents – Cont.

Chapter 6 – Testing and Repair

Measuring Airflow	6-1
Anemometers.....	6-3
Recommended Airflows and Correlation Chart.....	6-4
Exhaust Volume and Make-up Air Guidelines.....	6-5
Capture Performance Guarantee.....	6-6
UV Lamp Modules	6-7
Setting Pressure Switches	6-8
Spade Connector Adjustments.....	6-10

Chapter 7 – Parts

ELXC-SPC UV Module Assembly	7-1
ELXC-SPC 2000 CFM ESP Cell Assembly	7-2
ELXC-SPC Opacity Sensor Assembly	7-3
ELXC-SPC Sump Drain Assembly.....	7-4
Wash Control Cabinet – Detergent Pump.....	7-5
PCV Ballast Enclosure Assembly.....	7-6

Chapter 8 – Wiring Diagrams

Power Pack Enclosure/ESP Section	8-1
Ballast Box/Hood Sub-Assembly Connections	8-2
Ballast Box Enclosure with Optic Option.....	8-3
Ballast Box Enclosure without Optic Option	8-4
Wiring Diagram – C-7000 SPC Supplemental.....	8-5
Wiring Diagram – Multiple System GPC 7000 SPC.....	8-6
Wiring Diagram – UV Module	8-7
Wiring Diagram – DCA Control UV Module	8-7

Appendix

Installation Requirements	A-1
Start Up Requirements and Checklist	B-2
NYC Certificate of Approval.....	C-1
Limited Warranty	D-1

Introduction

About this Manual

The purpose of this manual is to provide the Operator, Owner, and Maintenance and Service personnel instructions for operating the ELXC-SPC series commercial kitchen ventilation system. For specific GPC-7000-SPC operations, programming, and maintenance please refer to the GPC-7000-SPC Command Center Technical Manual. This manual also includes information and guidance to contractors for initial installation of the hood.

The manual is divided into chapters for easy reference and the pages in the chapters are numbered with the chapter number, then a dash, and then the page number. For example, pages in Chapter 2 are numbered 2-1, 2-2, 2-3 etc. Figures and Tables are numbered in a similar manner. For example, Figure 5-3-2 is on page 5-3 and is the second figure. Please keep your manual in a convenient location so it can be accessed easily.

If you have any questions or concerns with the installation, operation, or service of your Gaylord Model ELXC-SPC series hood, please contact Gaylord Industries;

Web: www.gaylordventilation.com

E-Mail: info@gaylordventilation.com

Main Phone: 503-691-2010

Toll Free: 800-547-9696

Related Technical Manuals

1. GPC-7000-SPC Command Center. The specific manual for this Controller is titled **Operation and Maintenance Manual of Model GPC-7000-SPC Wash Control Cabinet.**
2. AirVantage Commercial Kitchen Demand Control Ventilation system. The specific manual for this Controller is titled **Models "DCV-AV" & "DCV-AVND" Series Operators Manual.**
3. **DCA Technical Manual** is the specific manual for the Gaylord Demand Control Autostart System.
4. **EMX Opacity Technical Manual** is the specific manual for the EMX Opacity System.
5. **CleanAir™ RSPC-TPF-(PCV) Series Technical Manual.**
6. Allanson High Voltage Power Supply Manual Titled **"-15kV / 10mA High Voltage Power Supply for Electrostatic Air Cleaner"** Specifications and Operating Manual.

Operation and Maintenance Manuals may be downloaded from the Gaylord Industries website: www.gaylordventilation.com or be obtained by contacting Gaylord Industries.

Description:

The ELXC-SPC hood is intended for installation over commercial type cooking equipment commonly listed to UL 197. It is designed to combine a Clean-In-Place commercial kitchen hood and a smoke and odor abatement device referred to as an Air Pollution Control Device in NFPA 96. Each hood section will incorporate a UL 300, or equivalent fire protection system (FP), which is activated upon detection of a fire on the cooking equipment or in the duct downstream of the hood. Each system, one or more hoods, shall be controlled by a GPC-7000-SPC Command Center and an optional Demand Control Ventilation System, AirVantage. Installation options are Wall-Mounted, Back-to-Back Island and Single Island. Single Island options are to be used only on medium or lesser equipment duties.

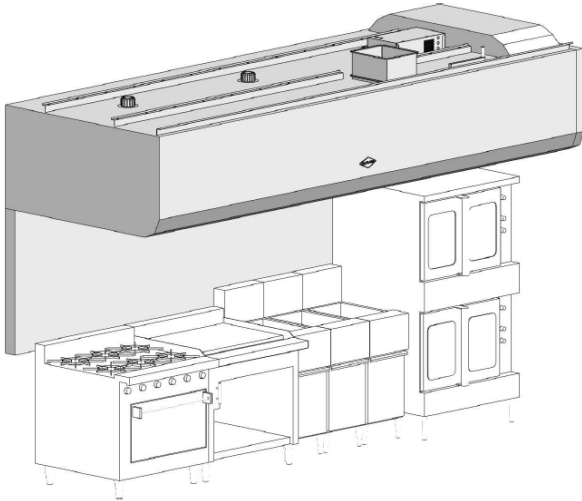

Figure 1-2-1 Wall Mounted

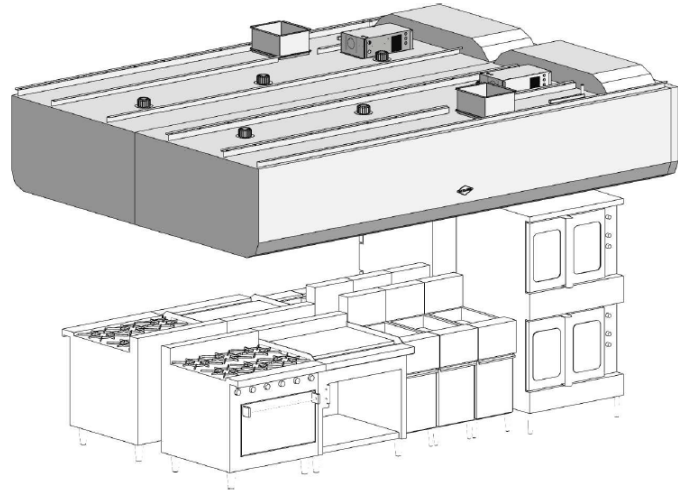

Figure 1-2-2 Back-To- Back Island



Figure 1-2-3 GPC-7000-SPC, Spray Odor Cabinet, and AirVantage Command Center



Figure 1-2-4 GPC-7000-SPC Control Cabinet

Model Number Sequence: - Understanding the Hood Model Number

Gaylord Ventilator model numbers are made up of an alphabetic prefix followed by a series of alphabetic and/or numeric suffixes to designate the style of ventilator and various options. Sequence of model numbers is as follows.

1. _____	2. _____	3. _____	4. _____	5. _____	6. _____	7. _____
Series	Damper	Style Option	Apron Design (If Applicable)	Duty (Equipment)	Controls (If Applicable)	Hood Depth (in)

Definition of Prefixes and Suffixes

1. **Series**

ELXC-SPC-SO.....	Water Wash Pollution Control Ventilator with UVi incorporating XGS Extractors, Single ESP Cell, Airflow up to 2000 CFM and 24-inch-deep front panel (<i>Single Odor – Single atomizing catalyst nozzle in plenum</i>)
ELXC-SPC-DO	Water Wash Pollution Control Ventilator with UVi incorporating XGS Extractors, Single ESP Cell, Airflow up to 2000 CFM and 24-inch-deep front panel and 2nd Atomizing Catalyst Nozzle at Duct Collar (<i>Double Odor</i>)
ELXC-SPC-Blank.....	Water Wash Pollution Control Ventilator incorporating XGS Extractors, Single ESP Cell, Airflow up to 2000 CFM, 24" deep front panel and NO Integrated UVi.
ELXC-SPC-CAN	Designed to Conform to Canadian CSA/ULC requirements, (5mA HVPS, Canadian French Labeling) <i>Water Wash Pollution Control Ventilator with UVi incorporating XGS Extractors, Single ESP Cell, Airflow up to 2000 CFM and 24-inch-deep front panel (Single Odor – Single atomizing catalyst nozzle in plenum)</i>

2. **Damper Type**

GBD (Standard)	Gaylord Balancing Damper. Mechanical balancing damper located at the duct collar
ND	No Damper
GBDAV..... Option)	Gaylord Volume Damper. Automated volume damper located at the duct collar (W/AV

3. **Style**

Blank	Wall Mounted Canopy Hood
CL	Single Island hood for Light and Medium duty cooking equipment utilizing a single extraction chamber. Description: Wall mounted hood design with finish back
BB.....	Back to Back Island Style for single or double equipment line up utilizing apron design airflows

4. **Apron Design Designation**

Blank.....	Capture Wall to be added below hood to extend down to 32 inches AFF
A	Hood to have an apron, which will terminate at the bottom lower edge of the canopy

5. **Duty Type**

Blank	(<i>If Applicable – 700°F Applications only</i>) Light, L-M, or Medium Duty lines - No cold-water mist
CM	Extra Heavy or Heavy - Cold Water Mist Manifold installed at the hood inlet

6. **Controls**

DCA	(<i>Automatic Start/Demand Control Option</i>) Indicates the hood is equipped with the second generation AutoStart system conforming with the IMC, IECC, and IGCC standards
AV.....	Indicates the hood is equipped with a listed AirVantage hood controller conforming with CA Title 24

7. **Hood Depth**

(##. ###)	(<i>Outside of Structural wall to front of hood canopy</i>) Value in inches to indicate the hood depth
------------------------	---

Model Number Sequence: - Continued

Note-1: Units with the “CAN” mark in the model number shall come equipped with a pre-limited High Voltage Power supply and Canadian French cautionary marking to meet all ULC and CSA requirements. As per CSA 22.2 #187, the unit’s power supply shall not exceed 5mA. Contact Gaylord Industries with any additional questions.

Note-2: Eliminators designed for use with heavy-duty equipment such as gas underfired broilers, Asian woks, or chain broilers may be designed with a supplementary odor control unit designated as model RSPC-TPF-(PCV) Series. Those units will require filter/carbon media, fire protection, and installation service as required in the **CleanAir™ RSPC-TPF-(PCV) Series Technical Manual**.

Figure 1-5-1 System Overview

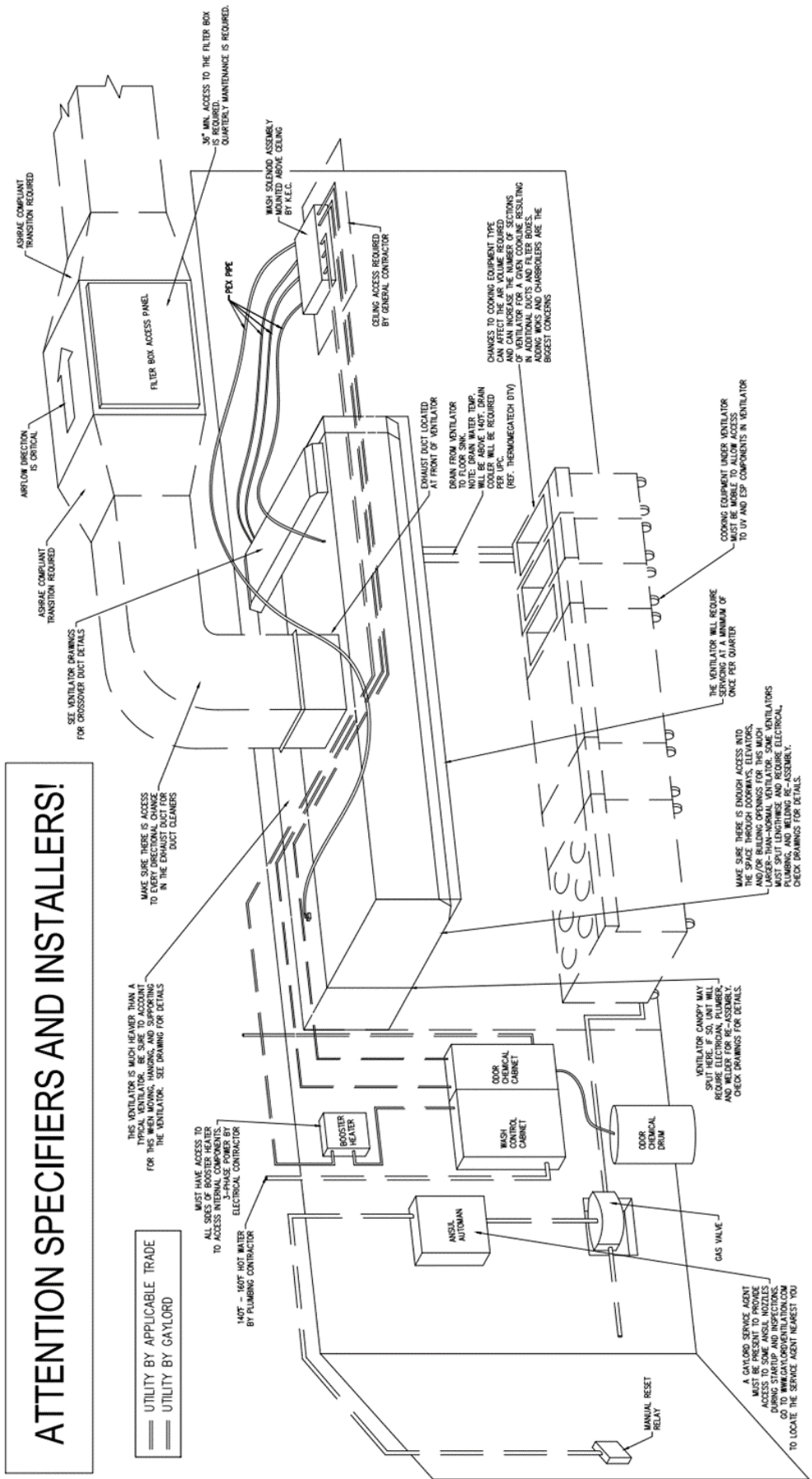

ATTENTION SPECIFIERS AND INSTALLERS!

Turning ON the Exhaust Fan:

CAUTION: Always turn on the exhaust fan before turning on the cooking equipment.

CAUTION: The chemical fire extinguishing system may discharge if the exhaust fan is not on while the cooking equipment is on or still hot.

CAUTION: Never operate your ventilator without the ESP Cell, UV module, or XGS Extractors in place or with the Extractor Access Doors open (refer to Figure 2-2-2).

Operation of the exhaust fan is controlled by the C-7000A-SPC Command Center, which is mounted in the Wash Control Cabinet, or, when equipped, by the AirVantage Command Center. To start the exhaust fan push **"START FAN"** on the Command Center. The Command Center control may be programmed to automatically start at a specific time. Refer to the Operation and Maintenance Manual for the Gaylord Command Center(s) for complete operating instructions.

NOTE: ELXC-SPC/*Eliminator* Series ventilators come standard with the means to automatically activate the exhaust fan when equipment is hot through the use of canopy-mounted temperature sensors (RTDs) designed into hoods with both DCA and AirVantage models. The Eliminator hood series is designed to meet the latest edition of NFPA-96, IMC, IFGC, UMC, and other mechanical codes. Consult Gaylord Industries for additional information.

Turning Off the Exhaust Fan

CAUTION: Always turn off the cooking equipment and allow to cool before turning off the exhaust fan. The chemical fire extinguishing system may discharge if the cooking equipment is on or hot when the exhaust fan is off.

At the end of the cooking day, turn off the cooking equipment and allow to cool before turning off the exhaust fan. To turn off the exhaust fan push **"STOP FAN"** on the C-7000A-SPC Command Center (Figure 2-2-1). The C-7000A-SPC Command Center control may be programmed to automatically turn off the exhaust fan at a specific time. When equipped with AirVantage, the fan will shut off automatically when there is no demand for exhaust for 15 minutes. Refer to the Operation and Maintenance Manual for the C-7000A Command Center or for the AirVantage System for complete operating instructions.

NOTE 1: Eliminator hood series fans will continue to run while equipment is hot or until the system has cooled sufficiently. Once complete the system will likely go into a wash phase. **NOTE 2:** Models equipped with AirVantage, once the fan is shut down, will stay OFF for the duration of the wash process and go into a one hour DRYING MODE once the washes have concluded. The fan will run at 100% for 1 hour with the ESP cells off once all daily washes have concluded.



Figure 2-2-1 Gaylord Command Center

Wash Cycle – Overview

ELXC-SPC series hoods have an integrated wash system that washes away the extracted grease within the smoke removal section (ESP Cell), hood plenum (UV lamps), and the UL 1046 XGS extractors (filters) with hot, detergent-injected water. The grease is flushed down the grease gutter which slopes to a drain line leading to the building wastewater system. **(Note:** Where code required, the Eliminator wash water will be discharged to a floor sink and in some cases will need to utilize a drain tempering device. Consult the drain tempering device operations and maintenance manual(s) to determine service intervals.

Each Eliminator hood section has three solenoid operated wash manifolds connected to a branch manifold (Figure 2-3-1) and plumbed in common with other hoods back to the Wash Control Cabinet GPC-7000-SPC. The GPC-7000-SPC is typically located in or near the kitchen. The GPC-7000-SPC houses the C-7000A-SPC Command Center, detergent pump, catalyst injection pump, detergent tank, other plumbing components needed to operate the wash cycles, and catalyst injection cabinet. A booster heater (Figure 2-3-2) will be installed between the GPC-7000-SPC and ELXC-SPC hoods prior to the first manifold to ensure the hood wash water temperatures are at or exceed 160°F. The Hubble Booster Heater comes field programmed to 165°F. Consult Hubble Booster Heater manual for programming, maintenance and installation requirements.



Figure 2-3-1 Wash Control Cabinet



Figure 2-3-2 Hubble JHX Series Booster Heater

Wash Cycle Sequence

The three wash manifolds, extractor wash, plenum wash, and cell wash (Figure 2-4-1), operate independently of each other as the extractor may need to wash more frequently than the others. Timers in the Command Center are programmed to initiate extractor wash as required *only* while the fan is operating, (FAN ON). The plenum and cell wash will run once daily; only when the fan is off. (FAN OFF)

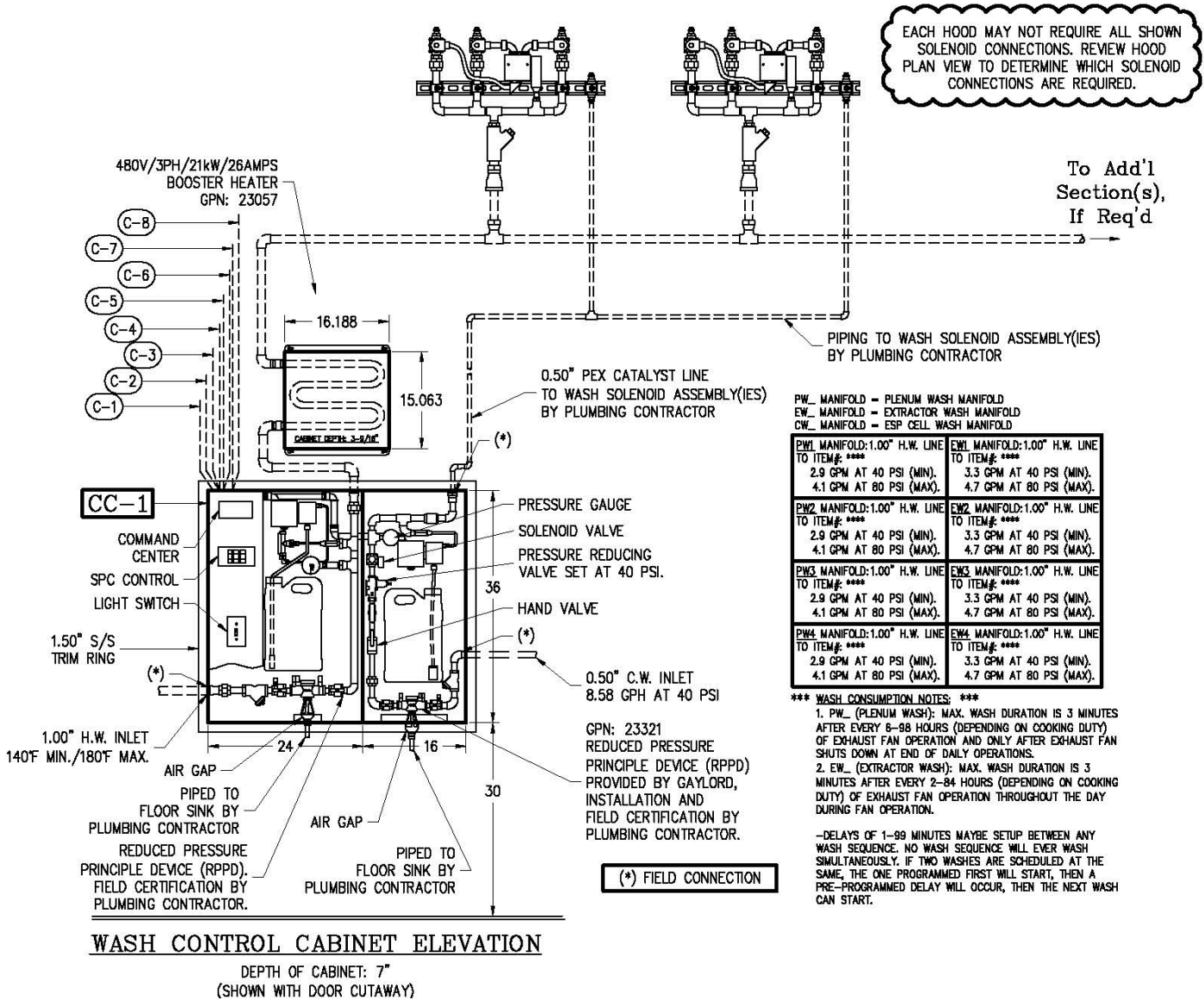

Figure 2-4-1 System Wash Layout

Wash Cycle Sequence – Cont.

PLUMBING NOTES

(P-1) WASH SOLENOID ASSEMBLY, BY GAYLORD, ATTACHED TO VENTILATOR BY FLEXIBLE PEX PIPING, EXTENDING 4' BEYOND FRONT OF VENTILATOR BY GAYLORD. WASH SOLENOID ASSEMBLY TO BE MOUNTED ABOVE THE CEILING BY PLUMBING CONTRACTOR.

(P-2) CEILING ACCESS TO WASH SOLENOID ASSEMBLY PROVIDED BY GENERAL CONTRACTOR.

(P-3) PLUMBING CONTRACTOR TO CONNECT 1.00" H.W. INLET ON WASH SOLENOID ASSEMBLY TO WASH CONTROL CABINET.

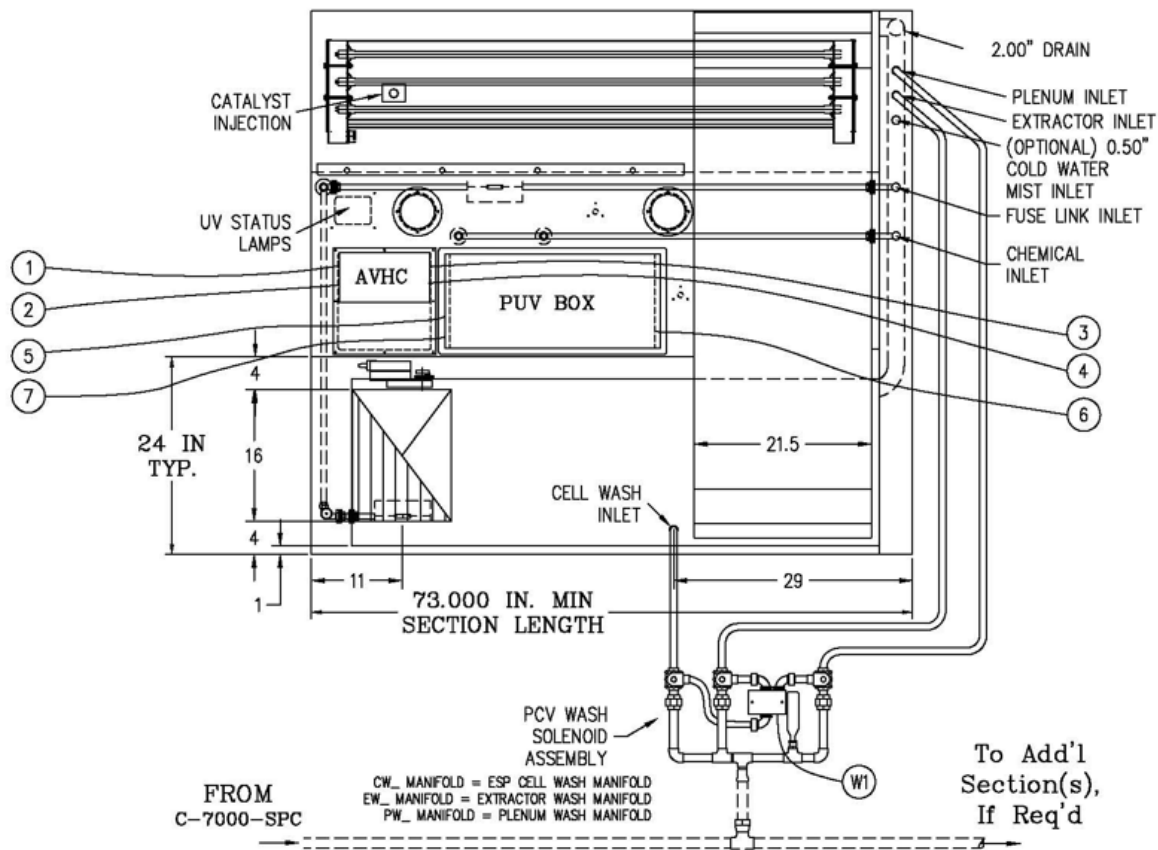

Wash Cycle Sequence – Cont.

The frequency and the length of the wash cycle are determined by the type of cooking equipment involved: Light Duty, Light/Medium Duty, Medium Duty, Heavy Duty, and Extra Heavy Duty. See the GPC-7000-SPC Technical Manual for procedure to set the wash type and duration. The wash sequence is based on hours of fan operation for specific duties of equipment to provide the optimum in cleaning performance with the lowest possible water and detergent consumption.

Wash Cycle Example

Extractor Wash Cycle – The extractor wash cycle only operates while the exhaust fan is on, typically during cooking. If the cooking equipment under the ventilator is heavy duty then the extractor wash will operate every four (4) hours of fan operation, stay on for three (3) minutes and then shut off.

Plenum Wash Cycle - The plenum wash cycle only operates while the exhaust fan is off and will occur in sequence with the cell wash process. The equipment duty type set at the GPC-7000 SPC Command Center, EX: “Heavy Duty”, will determine the length of the plenum wash.

Cell Wash Cycle - The cell wash cycle only operates while the exhaust fan is off and is set to run once daily. Each process will take three (3) minutes with a one (1) minute delay between washes for a total of eleven (11) minutes per hood section. If your kitchen contains three (3) hood sections estimate approximately a 35-minute shut down time to run all the washes followed by a one hour drying time.

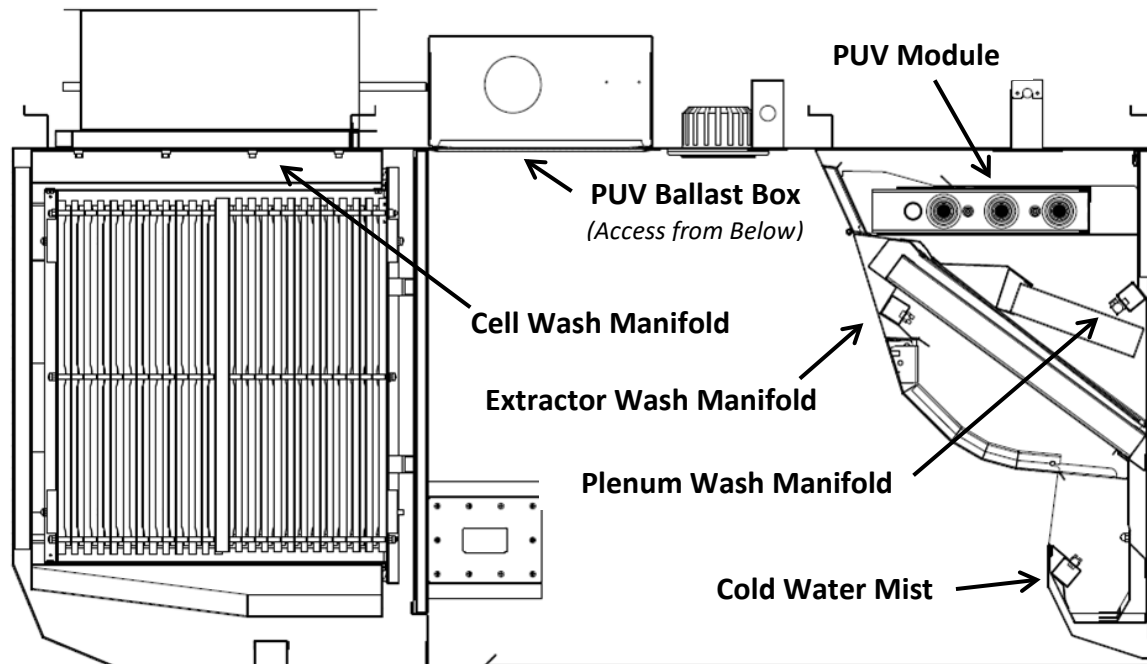

Figure 2-6-1 Wash Manifold Locations

Frequency and Length of Wash

The frequency of the wash and the length of the wash cycle is determined by the type of cooking equipment: Light Duty, Light/Medium Duty, Medium Duty, Heavy Duty, and Extra Heavy Duty. The number of hours before the wash cycle starts is based on average conditions. Table T-4-2-1 shows an example of typical frequencies and length of the wash times. Actual frequency necessary to adequately clean the ventilator may vary depending on the following:

1. Actual amount of cooking within the hours of fan operation.
2. Type of food product being cooked.
3. Water pressure; required pressure is 40 psi Min. to 80 psi Max.
4. Water temperature; required temperature is 140°F Min. to 180°F Max. (*Note Hubble Heater is designed to provide a 20°F increase in the water temperature. Target at the hoods is 160°F*)
5. Type of detergent; refer to page 2-17 for recommended detergent.
6. Ratio of detergent to water.

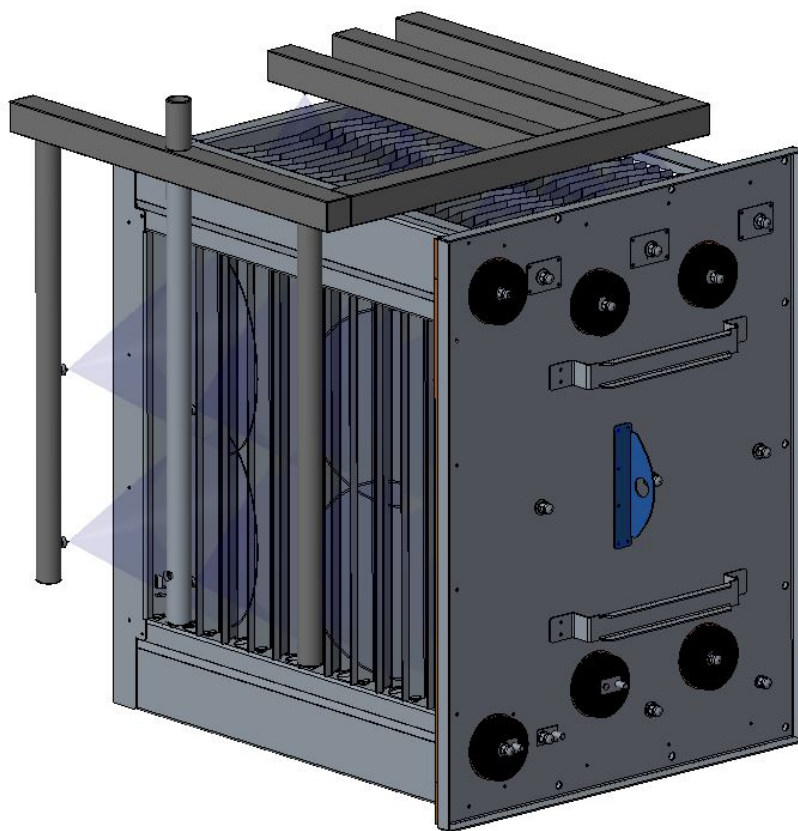

Figure 2-7-2 ESP Cell with Wash Manifold

Fire Protection Overview

Fire Damper

The ELXC-SPC hood is NOT equipped with a Fire damper. Suppression is by a UL 300, *or equivalent*, Fire Protection System ONLY.

Fire Extinguishing Systems

The National Fire Protection Association Standard 96 (NFPA-96) and the International Fire Code (IFC) requires the use of a Fire Extinguishing System to cover the cooking surfaces, ventilator exhaust plenums (area behind the grease extractors) and the exhaust duct (refer to Figure 2-8-1).

Upon activation of the Fire Extinguishing System by the breaking of a fuse link in the hood, or activation of a kitchen PULL Station, the follow will occur:

1. Fire extinguishing agent will discharge through the cooking equipment, plenum, crossover duct, ESP cell, and exhaust collar nozzles.
2. The protected cooking equipment and possibly other cooking equipment will shut off. Refer to the above referenced codes for specific equipment that must shut off.
3. If the Fire Extinguishing System is wired to a building fire alarm system, the alarm will activate.
4. If the Fire Extinguishing System is wired to a building management system, it will notify of a fire condition.

The Fire Extinguishing System should be wired to the Gaylord Command Center. If it is, the following will occur:

- 1) If the exhaust and supply fan are on, the exhaust fan will stay on and the supply fan will turn off. If the exhaust and supply fans are off, the exhaust fan will start, and the supply fan will stay off.
- 2) If the ventilator wash cycle is operating, it will shut down.
- 3) After discharge, the Fire Extinguishing System must be recharged and certified by a fire system contractor and all extinguishing agent cleaned up before the cooking equipment can be turned back on.

For Operation and Maintenance of the Fire Extinguishing System, refer to the system manufacturer's Owner's Manual.

Important: NFPA-96 requires inspection and certification of fire systems every 6 months.

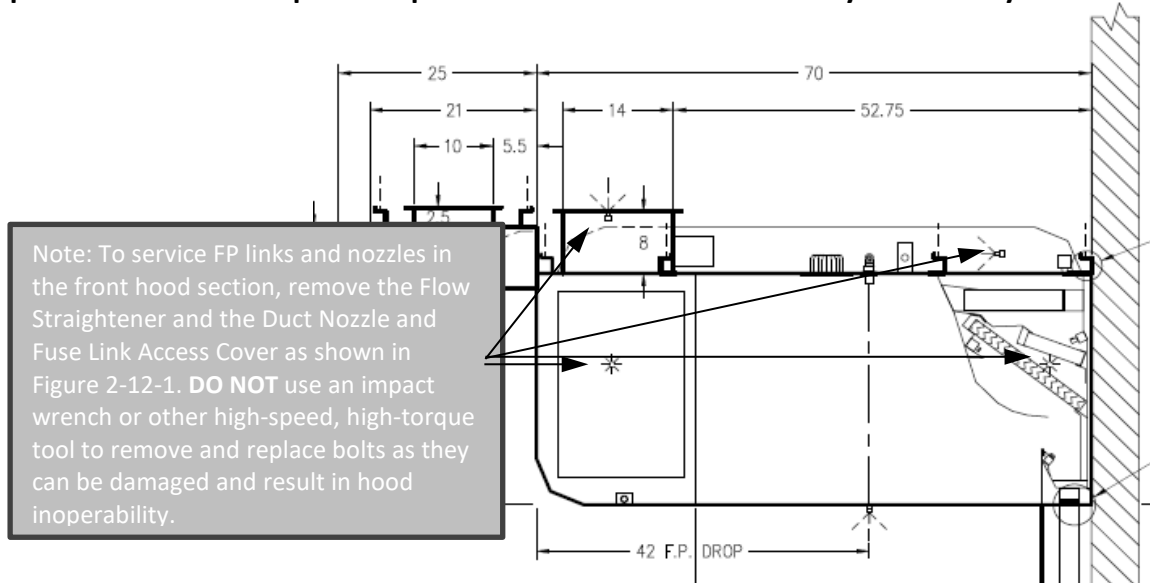

Figure 2-8-1 FP Nozzle Inspection Locations

Ultraviolet Systems Overview

Ventilators incorporating UV Lamps are designated Model ELXC-SPC-SO (single odor), ELXC-SPC-DO (double odor), ELXC-SPC-CAN (Canada). The pollution control UV (PUV) system is used to remove grease and abate odor. Three (3) UV lamps are mounted in a UV Module which slides into a track downstream, (after) the XGS extractors (refer to Figure 2-5-1). The electronics and ballasts for the UV system are mounted in a PUV ballast box which is located on the top of the ventilator (refer to Figure 2-5-1). The ELXC-SPC-SO ventilator is equipped with UV and ESP cell status lights to monitor the status of the UV System and safety interlocks mounted on the roof of the canopy.

For proper UV operation, the ventilators must be maintained in good working order. The UV system must be inspected monthly upon commissioning and as necessary once the loading is determined. The ventilator plenum, ductwork and exhaust fan must be inspected in accordance with NFPA-96 or local guidelines.

UV Safety

CAUTION: Exposure to UV light is harmful to skin and eyes.

The ELXC-UVi ventilator is equipped with panels and safety interlocks to protect operators from direct exposure to UV light. All safety precautions called for in this manual must be followed to avoid the potential for harm to operators or service personnel. ***NOTE:*** If at any time direct exposure to UV light is experienced shut the system down quickly to eliminate exposure because direct exposure to UV light is hazardous to your skin and eyes.

Ultraviolet Systems (UV) Cont.

UV Status Lights

Each ventilator section contains a bank of UV Status Lights to monitor the UV System (Figure 2-10-1). The system has three colored lights, blue, yellow and green, indicating system status:

1. **Green On:** The UV system is operating properly.
2. **Yellow On:** One or more UV Lamps are not operating, less UV is being generated, it does not prevent the operation of the ventilator or indicate an unsafe condition.
3. **Blue On:** One or more XGS Extractors are not in place and/or one or more UV module access doors are not closed properly and/or internal temperature of the ballast box has exceeded 118°F, which activates the high temperature shutdown controller. The blue light may also be activated when airflow has dropped due to a lack of demand as sensed by the DCV system. During this mode, the UV System is not operating and is in UV System standby mode until the cause has been corrected, or exhaust demand has increased.

In addition to the status lights on the ventilator, the Gaylord Command Center displays text indicating a similar message; refer to the Operation and Maintenance Manual for the Gaylord GPC-7000-SPC Command Center for complete operational instructions.

Note: If either the Yellow or Blue light are on while the fan is running, refer to the Troubleshooting section of this manual for corrective actions.

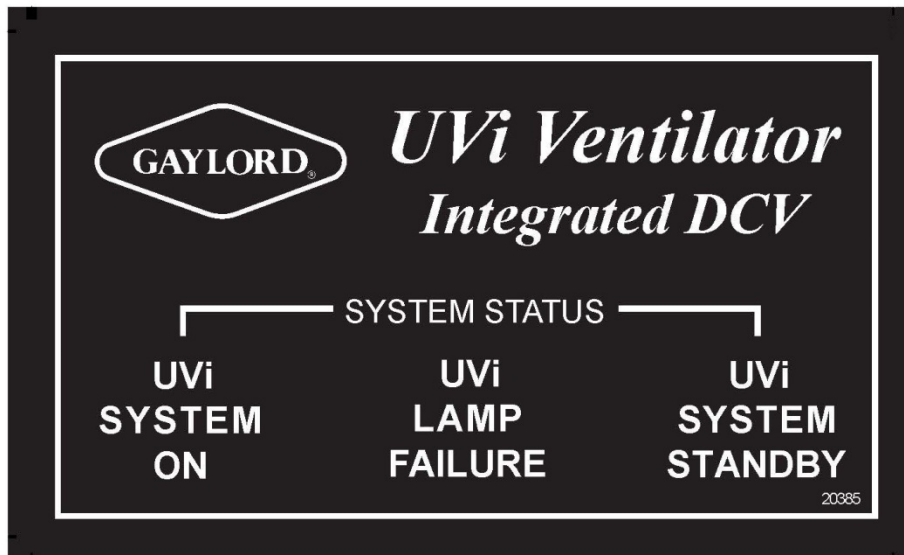

Figure 2-10-1 UV System Status Label

ESP Section

The ESP section, (Sump), is located in the front panel of the hood opposite the air inlet on the SPC ventilator. It uses high voltage to charge passing smoke. The charged smoke is electrostatically forced to the cell's ground plates. The collected smoke and grease particles are washed away by a wash system located at the top and front of the cell, see Figure 2-12-1. Insulators and ionizer wires are items subject replacement. The secret to keeping your ESP cells working effectively is a robust wash process and routine inspection and service as necessary. *(Note, a properly operating ESP cell will be communicated by the presence of a green status light on the front panel of each hood section)*



Figure 3-11-1 ESP Cell

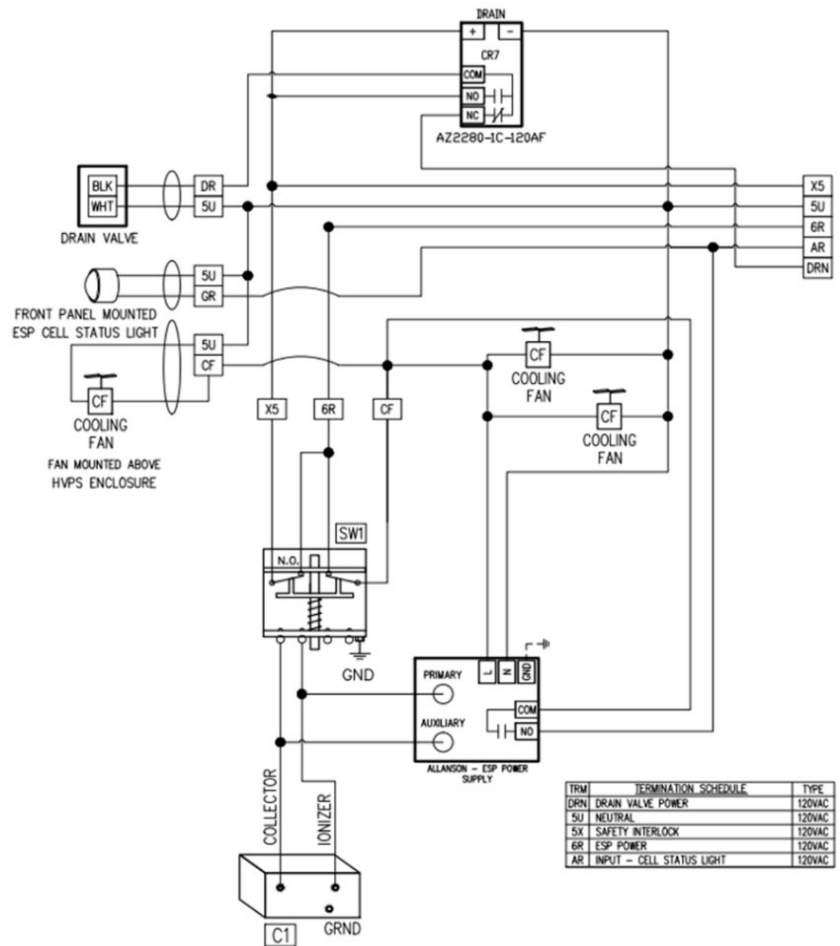

Figure 2-11-2 ESP Power Supply Wiring Diagram

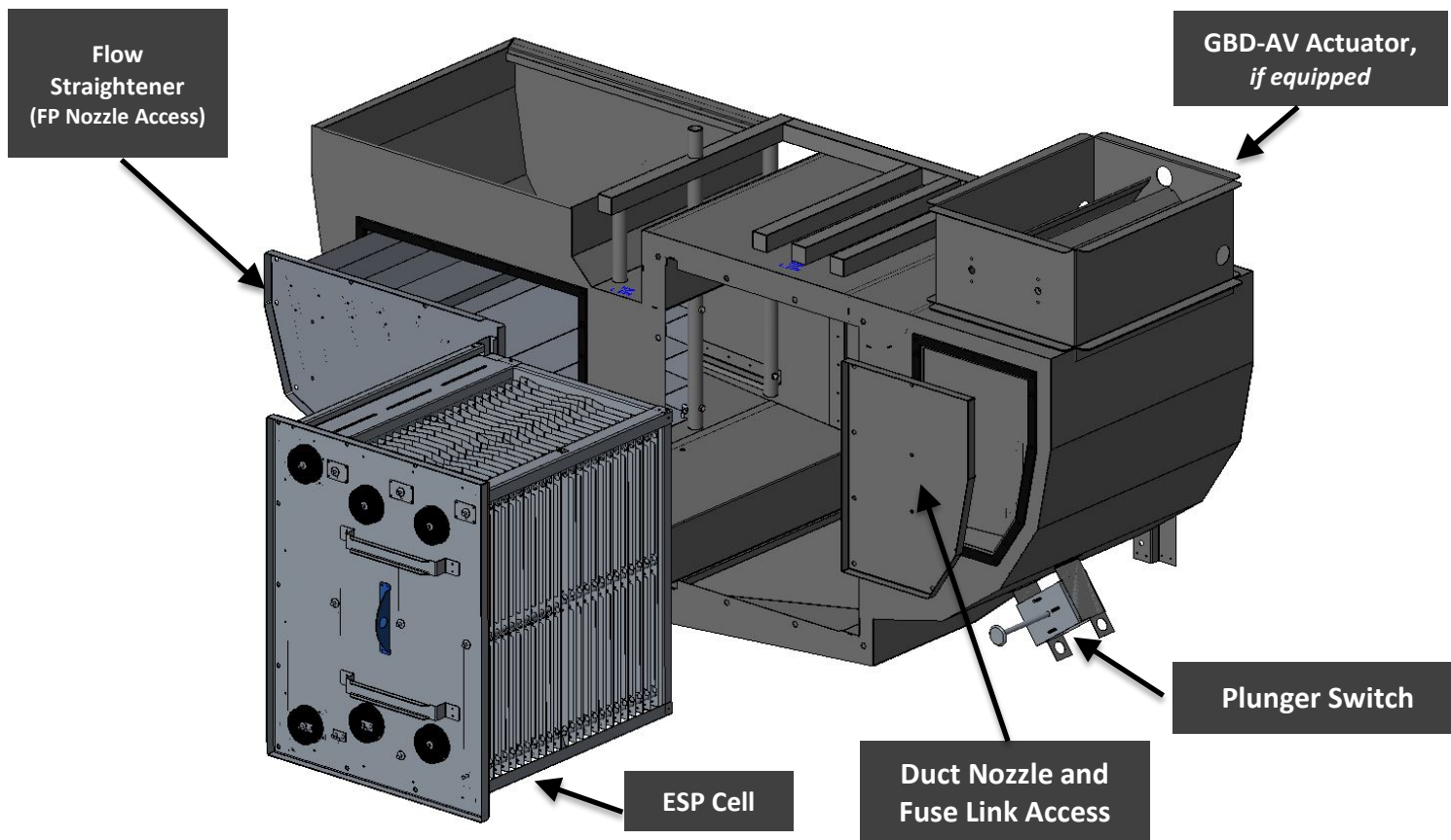

Figure 2-12-1 ESP Cell Housing

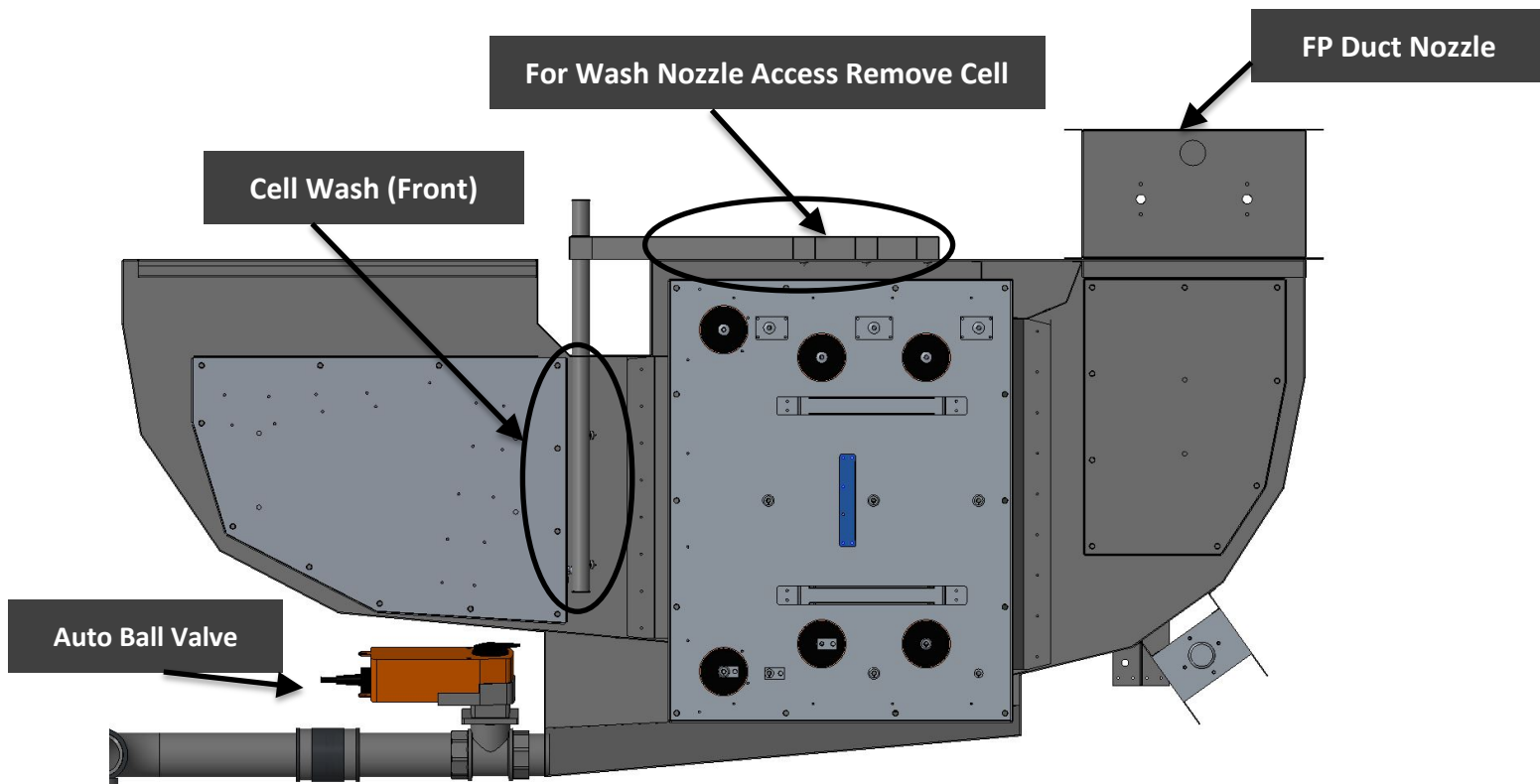

Figure 2-12-2 ESP Cell Housing

Opacity Sensor Overview

When equipped, the *optional* opacity sensor will sense smoke inside the hood canopy. When activated, the system triggers a full ramp-up to 100% for both the UV and catalyst injection systems. The increase in UV and catalyst input will continue for a period of five (5) minutes then ramp down if smoke is not detected. The sensor works by sending a beam of light across the inside of the plenum which detects visible smoke. Clear will be indicated with a "99" on the display. Display numbers "99 to 92" are acceptable with NO smoke present. With smoke present, the values will decrease and typical thresholds will be in the "60-85%" normal opacity range. See EMX Opacity Technical Manual for additional information.

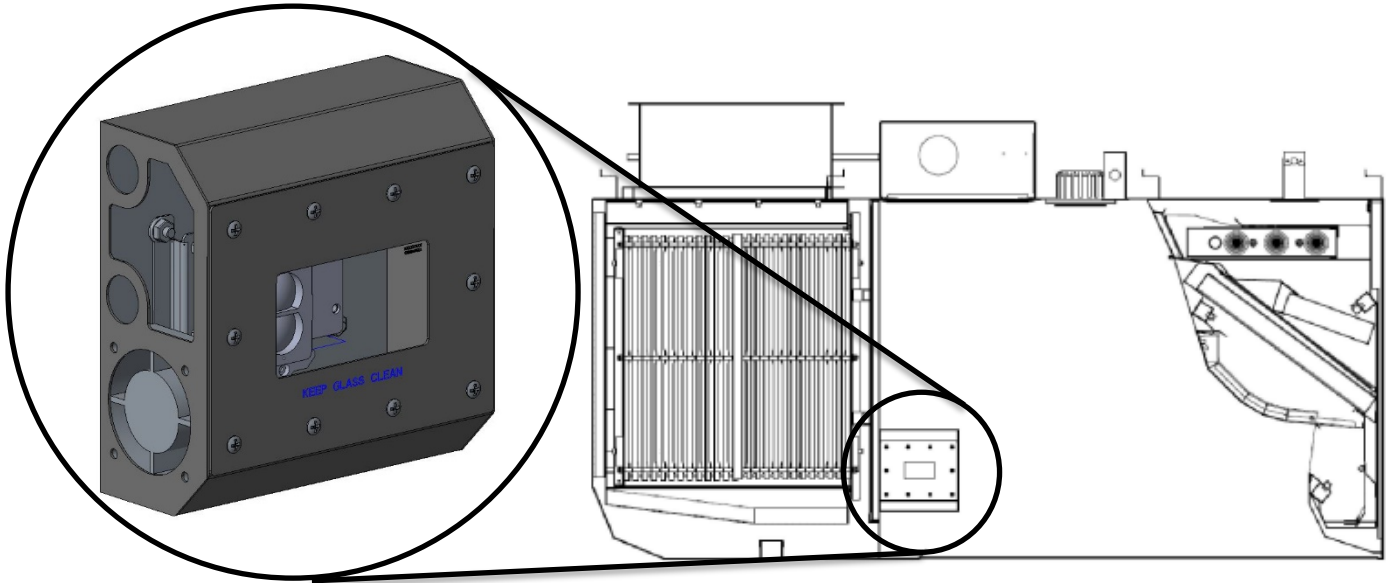

Figure 2-13-1 EMX Opacity Sensor Location

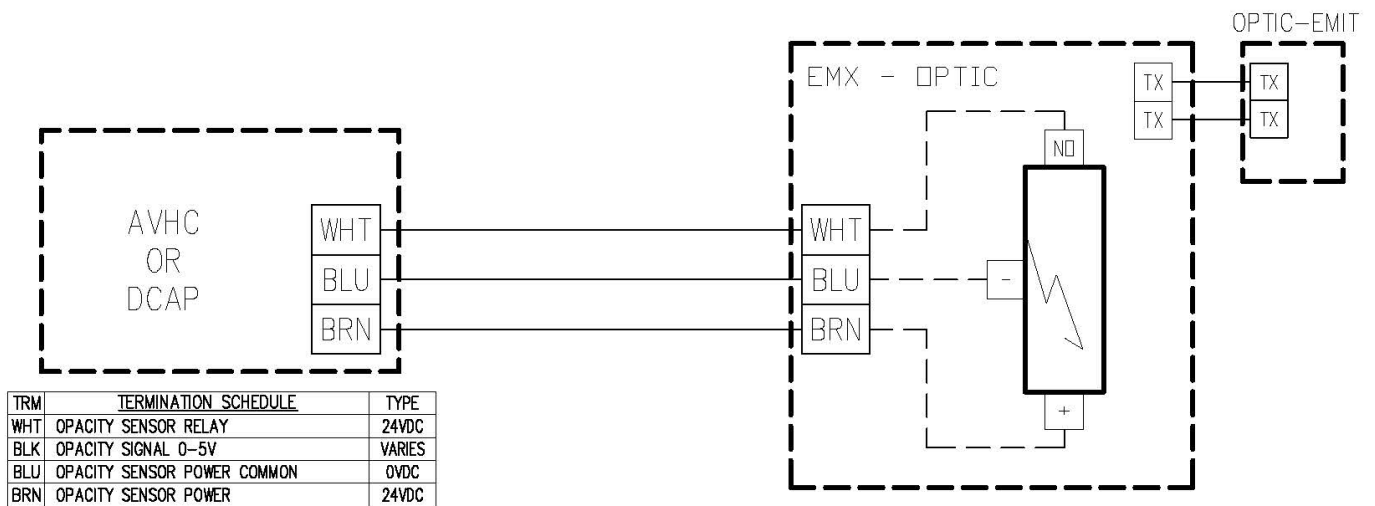

Figure 2-13-2 Opacity Sensor Wiring Diagram

Odor Abatement System (Catalyst Injection) Overview

Odor is targeted and removed in the ELXC-SPC hood by utilizing a combination of dimmable UV light and an atomized catalyst. The combination of the two systems breaks down and reforms odor causing compounds such as volatile organic compounds (VOC) and condensable grease.

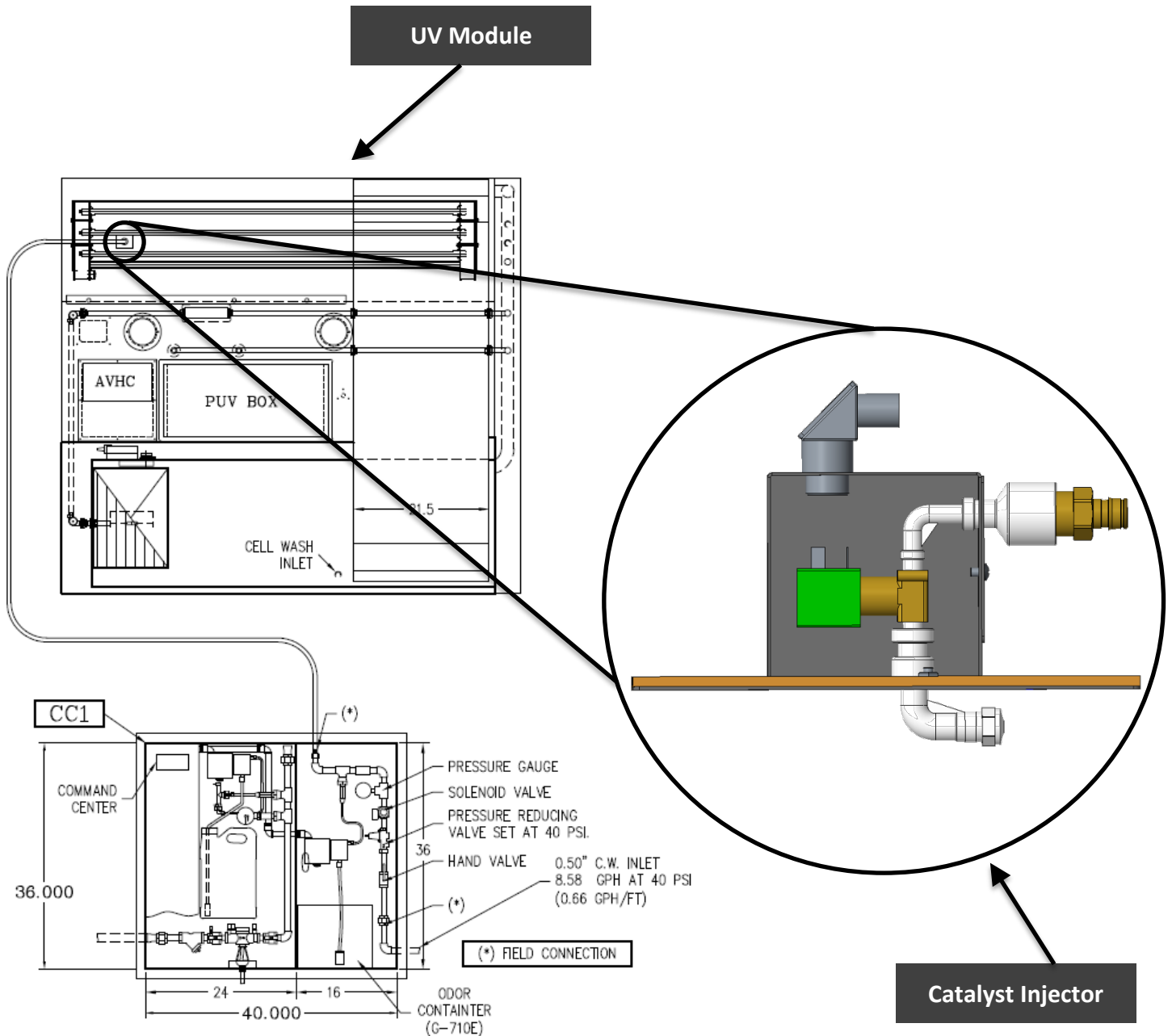

Figure 2-14-2 Catalyst Injection Overview

Operator Preventive Maintenance

Overview

To maintain the Gaylord ventilator in good working order and to keep the system operating at optimum efficiency, preventive maintenance, using the following schedule, **MUST** be performed. Initial inspections of the ESP Cell, UV module, filters, ducts, and when equipped, supplemental odor control unit will help determine the frequency of preventative maintenance schedule.

CAUTION:

Ventilators incorporating UV Lamps require special maintenance as shown on page 3-3. Some of the required maintenance on ventilators with UV can be performed by the operator. **NOTE: DIRECT EXPOSURE TO UV LIGHT IS HAZARDOUS** to your skin and eyes. Contact with live electrical components poses a significant risk of shock or death. Please deactivate the power to each hood section while servicing them.

Recommended Scheduled Maintenance

Table 3-2-1 ELXC-SPC Preventative Maintenance

ELXC-SPC Preventative Maintenance Tasks	
Daily	Opacity Sensor: Wipe down the Sensor Glass daily or as needed. Value should read in the 90s when clean. See figure 2-13-1 EMX Opacity Sensor Location.
	Confirm ESP Cell and UV lamp status lights are green.
	For general cleanliness the underside of the ventilator should be wiped down as shown in Figure 3-3-1.
	Verify the G-710E odor catalyst container/drum is full.
	Confirm there are NO alerts displayed on your GPC-7000 SPC Command Center.
	The detergent tank, located in the Wash Control Cabinet, should be checked and kept full of G-510EF detergent.
Weekly	Visually inspect the ventilator for water leaks and/or standing water.
	ESP/Smoke Removal section access door needs to be removed and the inside inspected for leaks and/or standing water. <i>(Extremely important to do after the unit has been serviced)</i>
Monthly	The detergent fittings should be checked. This is an airtight system and fittings should be tight. For complete details on the Detergent Pump refer to the Operation and Maintenance manual for the Gaylord Command Center and Wash Control Cabinet.
	When a wash cycle is not on, open the Extractor Access Doors and remove the extractors and particulate separators. (Refer to Figure 3-6-1). Check the extractors and plenum area to ensure they are being adequately cleaned. If the filters and particulate separators are not adequately clean, run through a ware wash machine or clean thoroughly in a deep well sink. If overall cleaning appears to be inadequate, refer to the Troubleshooting procedure in Section 5. Wash times or duty cycles may need to be adjusted. See Table T-4-2-1.
	Check the entire grease gutter and drain outlet and remove any foreign material such as paper towels, etc. Also check to ensure the gutter is being adequately cleaned by the wash cycle. If overall cleaning appears to be inadequate, refer to the Troubleshooting procedure on Page 4-2.
	Confirm all status lights are functioning properly. Verify lamps against notifications displayed at the GPC-7000 SPC Command Center.
	<i>(Heavy Duty sections, or as Needed)</i> Remove the ESP Section access door. Utilizing 7/16-inch socket, remove all ESP Cell bolts and carefully remove the unit to be inspected and cleaned in a deep well sink or Gaylord provided soak tank. CAUTION: The cell will weight in excess of 45 lbs. It is recommended that there be a safety spotter while removing the cell and care taken to not damage the cell plates or ionizer wires. A safety restraint system section 3-8 is provided by Gaylord to prevent the cell from being inadvertently dropped. Attach one end to the lifting eye on the cell, and the other to the recessed hook in the ceiling of the ventilator. Refer to page 3-8. <i>Note each louver in the front of the cell will have one ionizer wire present. If missing or damaged contact Gaylord Certified Service agent for replacements.</i>
Quarterly	While ESP cell is removed, inspect and wipe out the gutter under the ESP cell. Be careful to not force grease or other collected materials down into the drain producing a clog. Utilize safe drain cleaners or a snake to remove clogs.
	Gaylord CSA ONLY: Inspect catalyst nozzle for clog. Open the UV access door while fan is running. CAUTION: UV must deactivate once the door is opened. If lamps do not deactivate, STOP, close the access door and re-adjust the pressure switches. With door open and UV Lamps off, push front panel override to produce spray. If the spray is not present, refer to Troubleshooting to correct.
	Remove flow straightener and clean as necessary
	Check the exhaust fan(s) for belt tightness and alignment. Lubricate moving parts as required. Note: A blue lithium-based grease is best suited for high heat and speed bearing lubrication.
Every 6 Months	Confirm proper velocity at the air inlet slot. Refer to page 5-1 procedures. Hood's capturing okay?
	Clean the detergent tank and foot valve.
	Duct Inspection and Cleaning requirements, as per local requirement, see NFPA96/ IKECA Standards
Annually	Conduct all Quarterly & 6-month PM activities
	Pressure switch inspection. – See Section 5 Pressure Switches.

Inspection and Cleaning Requirements

NFPA-96 (Standard for Ventilation Control and Fire Protection of Commercial Cooking Operations) requires that hoods (ventilators), ducts and exhaust fans be **inspected** by a properly trained, qualified and certified company or person(s) in accordance with the following table.

Table 3-3-1

Exhaust System Inspection Schedule	
System Service Solid Fuel Cooking Operations	Monthly
Systems serving high-volume cooking operations (i.e. 24-hour cooking, charbroiling or wok cooking)	Quarterly
Systems serving moderate-volume cooking operations	Semi-Annually
Systems serving low-volume cooking operations (i.e. churches, seasonal businesses, or senior centers)	Annually

Upon inspection, if found to be contaminated with deposits from grease laden vapors, the entire exhaust system shall be cleaned by a properly trained, qualified, and certified company or person(s) acceptable to the authority having jurisdiction.

When a vent cleaning service is used, a certificate showing date of inspection or cleaning shall be maintained on the premises. After cleaning is completed, the vent cleaning contractor shall place or display within the kitchen area a label indicating the date cleaned and the name of the servicing company. It shall also indicate the area not cleaned. It is good practice to get before and after pictures for quality control purposes.



Clean All These Areas

Figure 3-3-1 ELXC Maintenance Areas

Personal Protective Equipment

1. Eye protection that prevents 100% of UV light from being transmitted through the lens must be worn at all times when replacing the UV Lamps on any ELXC-SPC ventilator that is energized and/or has the potential to be energized and expose personnel to UV light.
2. Whenever service work is performed it is recommended that long sleeve shirts and pants be worn to minimize the potential for inadvertent exposure of the skin to UV light.

Preventive Maintenance

The following Preventive Maintenance items must be performed by a trained and qualified Certified Service Agency at a frequency shown on page 3-3, Table 3-3-1, EXHAUST SYSTEM INSPECTION SCHEDULE. These tasks involve potential exposure to high doses of UV light and live electrical components. **There is a risk of shock, injury and/or death from contact with live electrical components.**

1. Testing UV Lamps and Ballasts

(For these tests all XGS Extractors must be in place, the Extractor Access Doors closed and all UV Module Access Doors in place and latched.)

- a. Turn on the exhaust fan at the Gaylord Command Center. The “UVi SYSTEM ON” green Status Light in each ventilator Section should be on. In addition to the Status Lights on the ventilator, the Gaylord Command Center should display text indicating the similar message as the Status Lights.

Testing UV Lamps and Ballasts - Cont.

- b. If the yellow “UVi LAMP FAILURE” Status Light is on one or more of the UV lamps are not operating. To troubleshoot and replace a lamp refer to the Troubleshooting Section 5 and Testing and Repair section of this manual beginning on page 6-7.
- c. If the blue “UVi SYSTEM STANDBY” Status Light is on one or more XGS Extractors are not in place and/or one or more UV Module Access Doors have not been closed properly or the internal temperature of the Ballast Box has exceeded 118°F which activates the High Temperature Shutdown Controller. Refer to Section 5 for troubleshooting and corrective action for the Temperature Shutdown Controller.

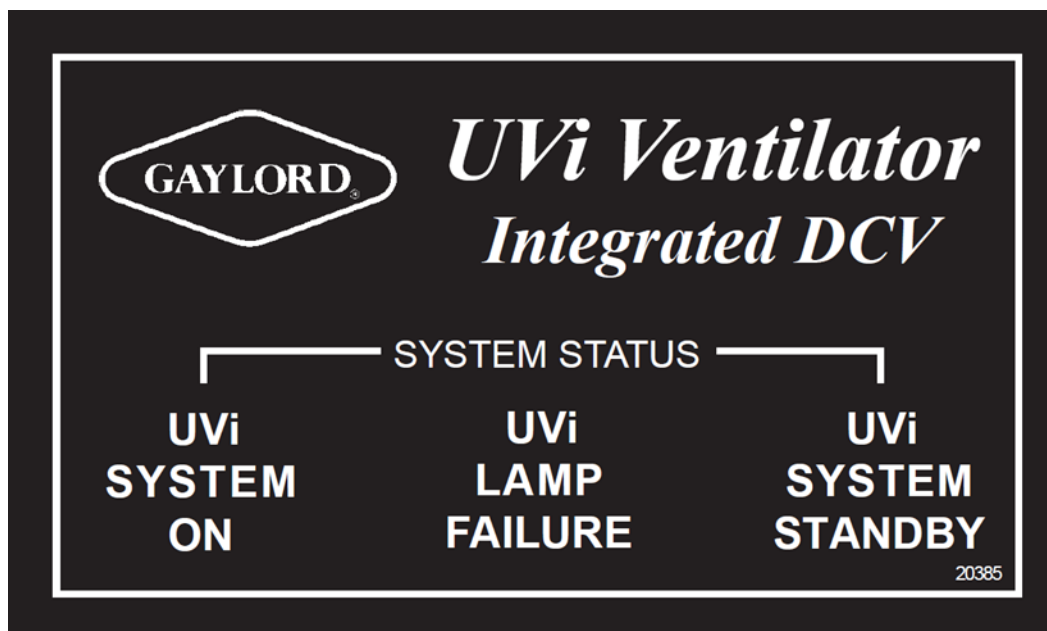

Figure 3-5-1 UV Status Light Label

2. Inspect and Clean UV Modules

- a. Turn off the exhaust fan at the Command Center.
- b. Open the UV Module access door(s) (refer to Figure 2-6-1).
- c. Disconnect the UV module lamp ballast connector.
- d. Remove the UV Module(s) from the ventilator. *(Caution: Care must be taken to keep the connector from hitting the lamps while removing the module.)*
- e. Using a damp non-abrasive cloth and mild detergent, wipe down the lamps and lamp housing. Lamps should be free of all grease and debris.
- f. Carefully inspect the UV Module access door and replace the gasket as needed to ensure a good seal.
- g. Reinstall the UV Module(s) being careful to not hit the Lamps.
- h. Reconnect the UV Module lamp ballast connector.
- i. Close the UV Module access door(s).

3. Test Safety Interlocks for the XGS Extractors (Pressure Switches)

(Caution: For the following tests Polycarbonate Safety Glasses must be worn.)

- a. Turn **ON** the exhaust fan at the Command Center. The “**UVi SYSTEM ON**” green Status Light in each ventilator Section should be on after a (1) minute delay.
- b. Open the Extractor Access Door at the left end of the ventilator remove one XGS Extractor. The blue “UVi System Standby” Status Light should come on, UV Lights will Shut OFF. If this action does not occur, immediately shut down the exhaust fan at the Command Center. Refer to section 6-8 “Setting UV Pressure Switches” or troubleshooting section of this manual for corrective action. Repeat tests 3a and 3b for the right most XGS Extractor and again for the center XGS Extractor. (**NOTE:** Fans must be running at 100% during the testing)
- c. If there is more than one ventilator section, repeat tests 3a and 3b for each section.

4. Test Safety Interlocks for the UV Module Access Panel (Pressure Switches)

(Caution: For the following tests Polycarbonate Safety Glasses must be worn.)

- a. Turn on the exhaust fan at the Command Center. The “UV System On” green Status Light in each
- b. Ventilator section should be on after a (1) minute delay.
- c. b. Open the UV Module Access Door (refer to Figure 2-10-2). The blue “UVi System Standby” Status Light should come on and UV lights shut down. If this action does not occur, immediately shut down the exhaust fan at the Command Center, refer to section 6-8 “Setting UV Pressure Switches” or Troubleshooting section, Chapter 5 for corrective action. (**NOTE:** Fans must be running at 100% during the testing)
- d. c. If there is more than one ventilator section, repeat the tests above, 4a and 4b, for each section.

5. Lamp Replacement

The UV Lamps need to be replaced after 13,000 hours of use for Medium or lighter duty systems, 8000 hours on Heavy/Extra-Heavy-duty systems, (Hood Sections). After 13,000/8,000 hours the lamps will still work but the performance of the lamps decreases dramatically. The Gaylord Command Center includes a built-in UV hours of operation clock. Refer to the Operation and Maintenance Manual for the Gaylord Command Center for complete operational instructions. If the lamps have been in use over 13,000 hours they should be replaced.

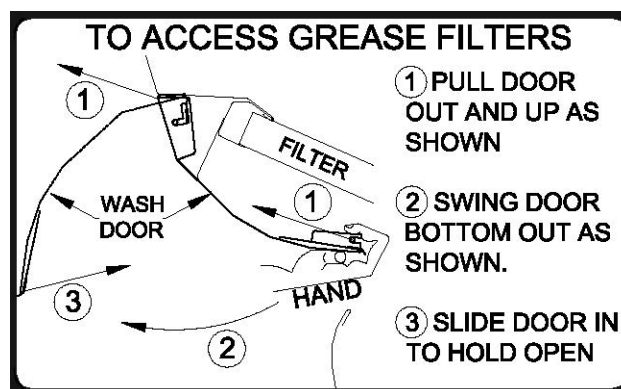

Figure 3-6-1 Open Extractor Access Door

ESP Cell Maintenance and Crossover Duct System Maintenance

Cell enclosure maintenance and inspection is to occur at the frequency detailed in Table T-3-2-1. Items detailed below in figure 3-6-1 are to be inspected and services as discussed below.

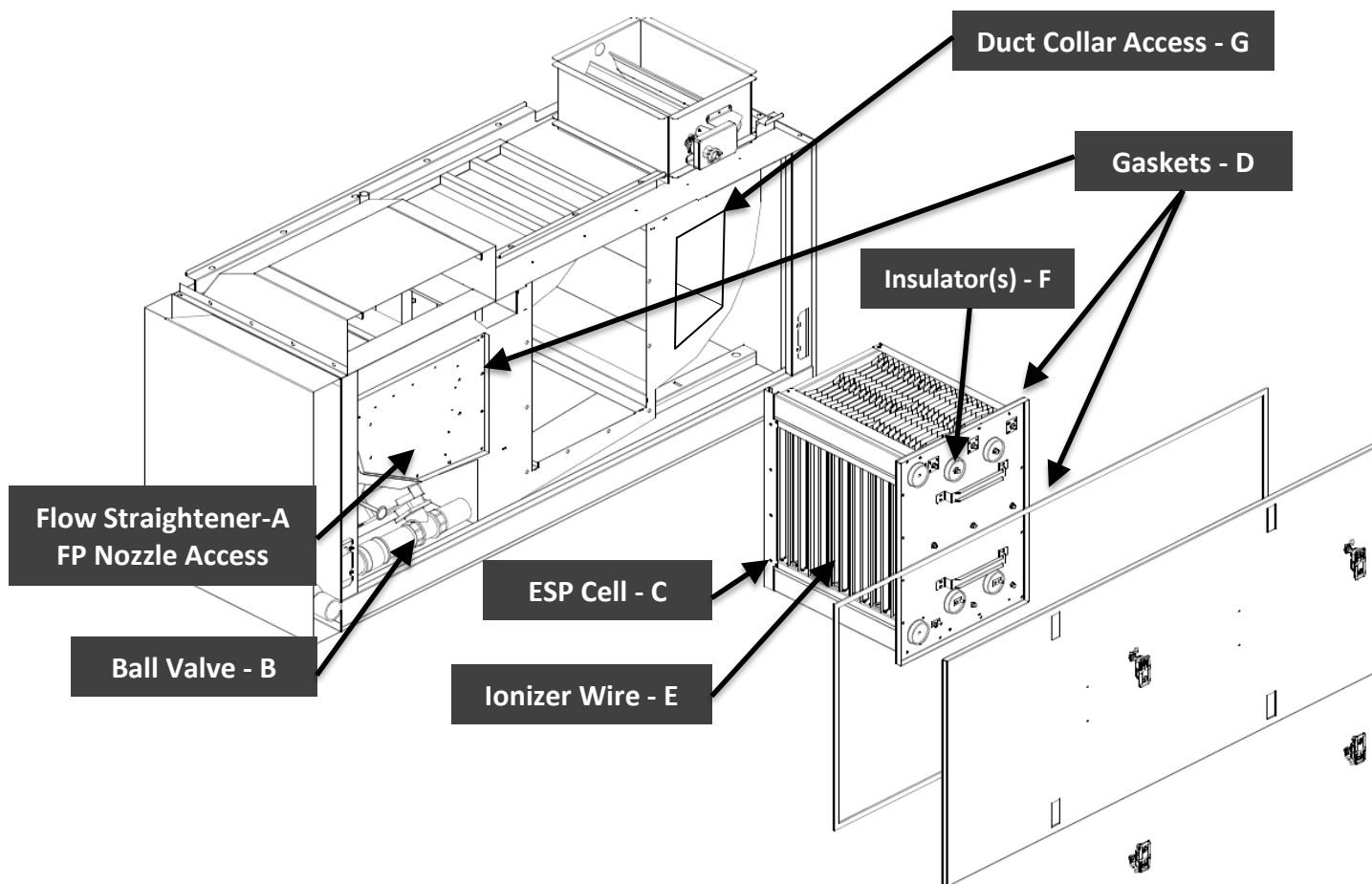

Figure 3-7-1 ESP Cell & Duct Maintenance

- Flow Straightener-A&D** service will require a powered 7/16" nut-driver on a drill motor. There will be 11 bolts to remove. Once bolts are removed, carefully remove the Flow Straightener and place on a covered surface. Inspect the unit's gaskets and any grease deposits or damage. If required, see *NFPA-96 guidelines*, wash the flow straightener in a deep well sink or other tank cleaning system. Wash until the unit is clean and free of debris. Inspect the inside of the unit and clean as necessary. Confirm gasket "D" is secure and in good condition prior to replacing back in the Cell Enclosure. With the Flow Straightener removed, inspect the cross over duct for deposition. Access from the behind the extractors and Flow Straightener (A). A mirror may be required. Clean as needed.

7. **ESP CELL – C, D, E & F** maintenance will require a powered 7/16-inch socket on a drill motor. There will be 16 bolts to remove. Once complete, carefully remove the ESP cell and place on a covered surface. Inspect the cell's ionizer wires ("E"), gaskets ("D"), insulators ("F") for deposits of grease, cracking or other damage. If required, wash the cell in a deep well sink or other tank cleaning system. **(Note: Utilize a pressure washer at your own risk. Systems with 1500 PSI or greater will cut holes into the plates and destroy ionizer wires when not properly utilized, see 3-7-2).** Wash until the unit is clean and free of debris. Re-install the cell carefully while not over torquing the 7/16", ¼-20 bolts, 5 ft lbs. max. Set your drill motor clutch to "13". **(NOTE: Ionizer wires must be installed properly and be in good conditions. A single missing or damaged wire will prevent adequate smoke removal or premature failure of the Odor Media)**



Figure 3-8-1 ESP Cell "Cautious Pressure Washing"

8. **Power Ball Valve – B:** Inspect the ball valve ("B") for obstructions and clogs. Confirm the Pre-Flush, (Copper Tube connected to the ESP Front wash manifold) is in place and working properly to shoot hot water and detergent toward the Ball Valve. If clogs are present use drain cleaner or a snake to free the line. Inspect Wash system for proper wash water temperature. Note: it is critical that this device works properly.
9. **Duct Collar Access – G:** Remove to inspect FP duct collar fuse link and duct nozzle.

Reinstallation of the ESP Cell – 7/16 nut driver, 5 ft-lbs max torque, tighten as shown below for proper seal into the hood.



Figure 3-9-1 ESP Cell Bolt Tightening Schedule – Re-installation

Eliminator ESP Cell Hoist Procedure

A manual chain hoist is provided by Gaylord Industries to assist in the removal and replacement of ESP during servicing operations. Refer to instructions included with hoist for further details.

1. Remove access cover in canopy to reveal recessed hoist attachment point, on the roof of the hood directly in front of the ESP cell, in the central area of the canopy ceiling.
2. Attach hoist hook to steel bar located inside the recessed hoist attachment point.
3. Attach opposing hook to attachment bracket located on front panel of ESP cell (shaded blue).
4. Adjust chain to remove slack.
5. Grasp handles on cell to pull out of sump and gently suspend it from hoist.
6. Move flipper on hoist to downward arrow position (toward floor). **NOTE:** When flipper is in "neutral" position (between up and down arrows), the chain can be raised or lowered manually with braking capability.
7. Use ratchet bar to lower cell toward ground. **NOTE:** Hoist chain has 60 inches of travel.
8. For reinstallation of cell, reverse steps 7-1, but move flipper position on hoist to the "up" position.
9. Replace access covers and tighten nuts.

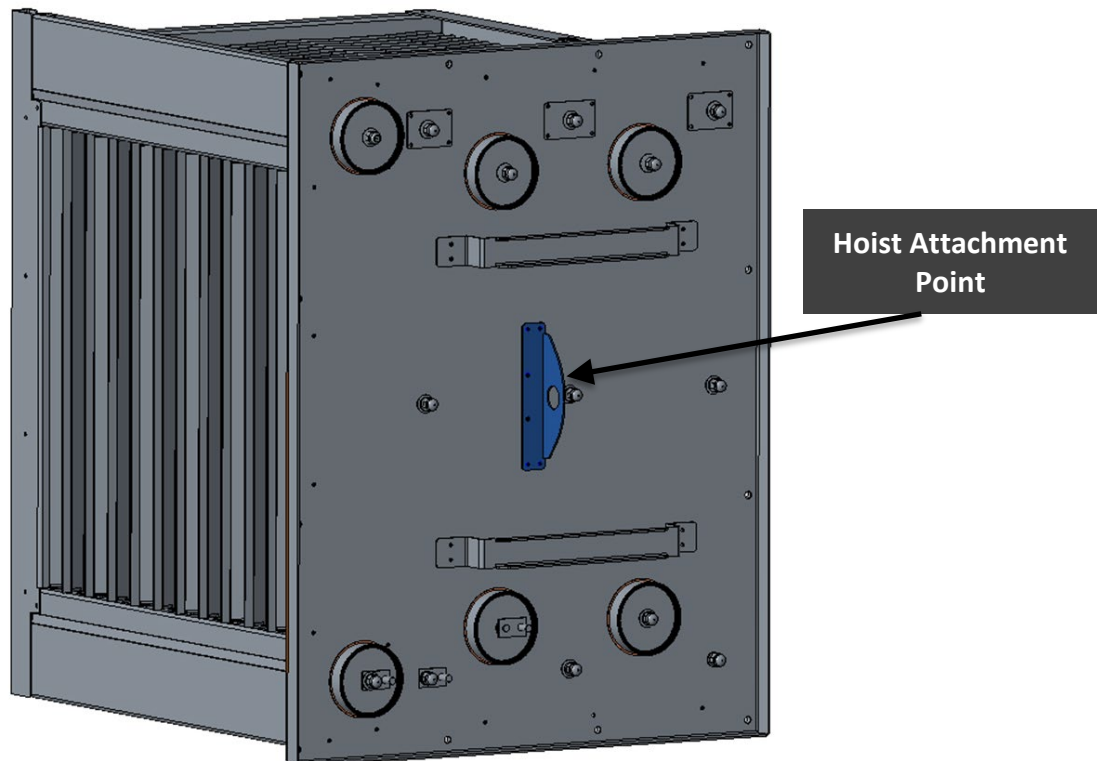

Figure 3-10-1 ESP Cell Hoist Diagram

Operator Settings and Adjustment Overview

This section details the settings and materials of the hood and cell Clean-In-Place systems as well as the catalyst injection systems. Setting parameters properly will insure effective smoke and odor removal and maintain minimal operational costs.

Note: *Making System adjustments is recommended to be done by reviewing initial system performance and adjusting to optimize the performance of the system while minimizing the required resources such as detergent and GS 710E. Parameters such as cell status lights deactivating shortly after being commissioned, dirty ducts, or premature failures of the supplemental odor control unit media or filtration, all would be indicators that the system requires adjustment.*

Table 4-2-1 ELXC-SPC Wash Times

Models ELXC-SPC Wash TIMES CHART (Set at the GPC-7000 SPC Command Center)										
Frequency and Length of Wash Cycles (Typical Example)										
Cooking Equipment Duty	Extractor Wash		Plenum Wash		CELL Wash (Notes 6, 7, and 8)					
	Hours of Fan Operation Before Wash Starts	Length of Wash Cycle (min)	Hours of Fan Operation Before Wash Starts	Length of Wash Cycle (min.)	Each Cell washes in the following sequence. If the ELXC-SPC has two ESP Cells, the wash sequence repeats for manifold #2.					
					Wash (min)	Delay (min)	Wash (min)	Delay (min)	Rinse (min)	Delay (min)
	Factory Set	Note 1	Factory Set	Note 1	Note 1	Note 2	Note 1	Note 2	Note 3	Note 2
Light Duty Ovens, steamers and kettles	84	3	98	3	3	3	3	3	3	10
Light / Medium Duty Braising pans, tilting skillets, fryers, open burner ranges, hot top ranges, and conveyor ovens	42	3	72	3	3	3	3	3	3	10
Medium Duty Griddles, grooved griddles	12	3	36	3	3	3	3	3	3	10
Heavy Duty Gas and electric char-broilers, upright broilers, woks and conveyor broilers	4	3	16	3	4	3	4	3	4	10
Extra Heavy Duty Solid fuel broilers	2	3	6	3	5	3	5	3	5	15

Wash System Continue:

Note 1: Cell wash cycles may be programmed for between 3 and 10 minutes.

Note 2: The delay period between Washes may be programmed for between 1 and 99 minutes.

Note 3: The rinse cycle is Factory set for 3 minutes and cannot be changed.

Note 4: The ventilator extractor and Plenum Washes may be programmed for between 3 and 10 minutes.

Note 5: All washes and delays may be programmed at the Owner/Maintenance Level 2.

Note 6: Cell washes are always programmed as a plenum. (EX: (1) ELXC-SPC hood will use PW1-Plenum wash 1, EW1, Extractor wash 1, and PW2 as the cell wash. EW2 will be unused.

Note 7: The wash frequency may be programmed as Light Duty, Light/Medium Duty, Medium Duty, Heavy Duty or Extra Heavy Duty.

Model ELXC-SPC Series Ventilator Water Consumption Table		
Type of Wash	<i>GPM or GPM/ ft. of Hood</i>	
	@40PSI	@80PSI
Extractor Wash (GPM/LF)	0.51	0.72
Plenum Wash (GPM/LF)	0.45	0.63
Cell Wash (GPM)	4.8	6.6
<i>*Cell Wash - Wash/Wash/Rinse</i>		
<i>* All Pressures Measured at the Wash Control Cabinet with 1" pipe line between the ventilator and Wash Control Cabinet</i>		
Hot Water Requirements		
Water Temperature: 140°F Min. to 180°F Max.		
Flow Pressure: 40 PSI Min. - 80 PSI Max. at the Wash Control Cabinet while in a Wash Cycle		

Recommended Detergent

FORMULA G-510EF is the only cleaner recommended by Gaylord Industries for use in the wash down system of The Gaylord ventilator. FORMULA G-510EF is a concentrated colloid cleaner specially formulated to remove the daily accumulation of grease inside the ventilator without damaging the rubber and synthetic parts of the solenoid valves and the detergent pumping system. FORMULA G-510EF is safe for kitchen personnel and has a variety of uses.

Table 4-3-1 Water Consumption Table

Table 4-4-1

CAM Setting Guide		
ELXC-SPC Estimated Odor Consumption/Hood Chart		
Equipment Duty	CAM/ Setting (*)	Consumption (**)
SO- Light Duty	0	UV Only
SO - Medium Duty	0.5	14 oz./day
SO - Heavy Duty	1	28 oz./day
SO- Extra Heavy	1.5	42 oz./day
DO - Heavy Duty	2	56 oz./day

**Cam Adjustment done in GPC-7000 SPC Cabinet in the odor section.*
***Values are based on activity levels and type of equipment. Settings must be calibrated against acceptable odor discharge results. Set based on highest duty level utilized in kitchen.*



Figure 4-4-2 Cam Adjustment

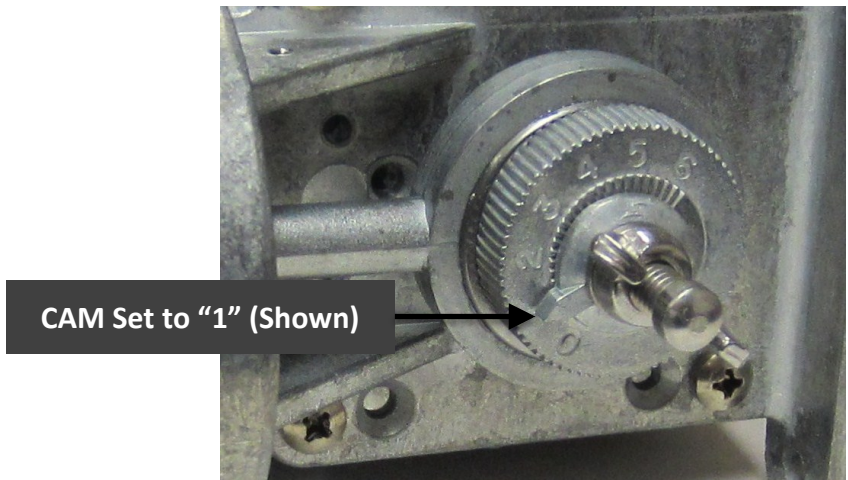





Figure 4-4-3 Cam Setting

Important Note: This label is mounted on the inside of the hood canopy, typically to the right. Items such as requires section airflow, electrical connections, listings, proper overhangs and hood static pressure will all be present here.

**HOTTE D'ASPIRATION
SANS REGISTRE DE TIRAGE**

CETTE HOTTE NE PEUT PAS ÊTRE UTILISÉE SANS UN SOUS-ENSEMBLE COMPRENANT UNE ARMOIRE DE COMMANDE RÉPERTORIÉE, MODÈLE GPC-7000-SPC.

CETTE HOTTE D'ASPIRATION A ÉTÉ CERTIFIÉE SELON LES NORMES UL 710 "HOTTES D'ASPIRATION POUR L'ÉQUIPEMENT DE CUISSON COMMERCIAL", UL 710C "LAMPES À RAYONS UV SERVANT À LA RÉDUCTION DES VAPEURS GRASSES ÉMISES PAR L'ÉQUIPEMENT DE CUISSON, ET UL 867 "ÉPURATEURS D'AIR PAR ÉLECTROSTATIQUE".

CERTIFIÉE POUR UTILISATION À DÉGAGEMENT ZÉRO DES MATÉRIAUX COMBUSTIBLES À L'AVANT, À L'ARRIÈRE, ET SUR LES CÔTÉS, AINSI QU'AUTOUR DE L'ENCEINTE ÉLECTRIQUE UV SI CONSTRUITE SELON LES DÉTAILS DU RAPPORT DE CERTIFICATION DU MANUFACTURIER.

CETTE HOTTE RÉPOND À TOUTES LES EXIGENCES DE L'ÉDITION LA PLUS RÉCENTE DE LA NORME NFPA-96 ET IMC (CODE INTERNATIONAL DE MÉCANIQUE).

LES INDUSTRIES GAYLORD
10900 S.W. AVERY STREET
TUALATIN, OR 97062 USA
(800) 547-9696
COURRIEL : info@gaylordventilation.com
www.gaylordventilation.com
BREVET EN INSTANCE

ELXC-SPC040617 / 23506

DONNÉES D'INGÉNIERIE

N° DE MODÈLE		ELXC-SPC-	
N° DE SÉRIE			
1. VOLUME MINIMAL D'ASPIRATION TOTALE SUGGÈRE POUR CETTE SECTION		PI ³ /MIN	
2. PRESSION STATIQUE D'ASPIRATION AU COLLET D'ÉCHAPPEMENT		2,00 CE	

TEMPÉRATURE MAX. DE LA SURFACE DE CUISSON	SERVICE LÉGER	400°F (205°C)	600°F (315°C)	700°F (370°C)
GAMME ELXC-SPC	VALEURS MINIMALES INDIQUÉES EN PP/MIN PAR PIED DE HOTTE LINÉAIRE			
MONTÉE AU MUR EN DÉBORD AVANT/CÔTÉ, (PO), *AVEC PLEIN PANNEAU LATÉRAL	6 0*-6	6 0*-6	6 0*-6	9 6
MONTÉE AU MUR AVEC MUR DE CAPTURE	100 100	122 131	195 217	252 214
MONTÉE AU MUR / BB GAMME "A"	108 108	132 141	214 234	232 280
ILOT SIMPLE EN DÉBORD, (PO), AVANT, ARRIÈRE & CÔTÉS	12 12	12 12	12 12	S.O.
ILOT SIMPLE HOTTE DE LA GAMME "CL"	120 -	210 -	314 -	S.O.

PRUDENCE - RISQUE DE CHOC ÉLECTRIQUE - IL FAUT PLUS D'UN SECTIONNEUR POUR DÉSACTIVER LE DISPOSITIF AVANT UN ENTRETIEN.

DÉBRANCHER AVANT TOUT ENTRETIEN : GPC-7000 SPC - COMMANDES DE LA HOTTE/LAMPES 120 VOLTS - COURANT ÉLECTRIQUE 120 VOLTS DES LAMPES À UV. CONSULTER LE MANUEL TECHNIQUE DE GAYLORD ET LE SCHÉMA ÉLECTRIQUE C-7000 SPC POUR PLUS DE DÉTAILS.

1. CONSULTER LE MANUEL TECHNIQUE DU VENTILATOR GAYLORD POUR LA OU LES MÉTHODE DE VÉRIFICATION DES VOLUMES D'AIR.
2. AVERTISSEMENT - UN VERROUILLAGE ÉTÉ PRÉVU POUR RÉDUIRE L'EXPOSITION EXCESSIVE AUX RAYONS ULTRAVIOLETS. NE PAS CONTOURNER CE VERROUILLAGE.
3. CONSULTER LE MANUEL TECHNIQUE DU VENTILATOR GAYLORD POUR L'INSTALLER ET L'ENTRETIEN CORRECTEMENT ET POUR DES CONSIGNES DE SÉCURITÉ.
4. À MOINS D'INDICATION CONTRAIRE, LES DÉBORDS SONT DE 6 PO À L'AVANT ET 6 PO LATÉRALEMENT. CEUX DE LA HOTTE EN ILOT "CL" SONT DE 6 PO À L'AVANT ET DE 12 PO LATÉRALEMENT.
(VOIR LEUR POSITIONS CI-DESSOUS).
5. S'IL FAUT LES REMPLACER, NE PAS UTILISER D'AUTRES FILTRES PRIMAIRES ET SECONDAIRES QUE CEUX DE GAYLORD.

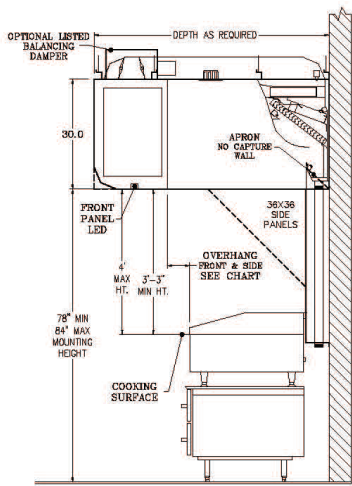

VUE EN COUPE

Figure 4-5-1 Ventilator Name Plate for ELXC Series Ventilators

Recommended Detergent

Overview

Formula G-510EF is the only cleaner recommended by Gaylord Industries for use in the wash down system of The Gaylord ventilator. Formula G-510EF is a concentrated colloid cleaner specially formulated to remove the daily accumulation of grease inside the ventilator without damaging the rubber and synthetic parts of the solenoid valves and the detergent pumping system. Formula G-510EF is biodegradable, safe for kitchen personnel, and has a variety of uses.

FORMULA G-510EF Safety

FORMULA G-510EF meets the stringent criteria of the U.S. Environmental Protection Agency's (EPA) Design for the Environment program – a program that works with manufacturers to develop safer chemical products that also meet high performance standards. The design for the Environment (DfE) label allows consumers to quickly identify and choose effective products that are safer for families and pets and help protect the environment.

When you see the DfE label on a product, it means that EPA's scientific review team has evaluated every ingredient for potential human health and environmental effects and allowed only chemicals from the safest in their class, that meet stringent EPA criteria to be used. DfE labeled products do not contain known chemicals of potential concern, like carcinogens, reproductive or developmental toxicants and even minor product components, like dyes and fragrances, are screened for safety.

Formula G-510EF for the Ventilator Wash System

Pour FORMULA G-510EF directly into the detergent tank located inside the Wash Control Cabinet. The detergent pump injects the detergent into the Main Feed Line where it dilutes with the hot water at the proper ratio.

Formula G-510EF for Cleaning the Ventilator Exterior

Mix one-part Formula G-510EF to twenty parts water in hand spray bottle. Spray on, let stand for a few minutes and wipe off.

Formula G-510EF for Other Cleaning Jobs

The colloidal action of Formula G-510EF makes it a cleaner especially well-suited for use in kitchens. The colloids break up dirt and grease into millions of tiny particles that constantly repel each other. These particles cannot recombine or redeposit on a surface and are, therefore, easily washed away. Formula G-510EF is biodegradable and contains no harsh chemicals yet offers outstanding performance on the toughest cleaning jobs.

Use a mixture of one-part Formula G-510EF to twenty parts water for:

- VINYL/PLASTIC/WALLS...Removes dirt, grease, food deposits and fingerprints.
- REFRIGERATORS...Removes dirt, spilled milk, blood, mildew and objectionable odors.
- RESTROOMS...Add a disinfectant to clean all fixtures, walls, floors, etc.

Use a mixture of one-part Formula G-510EF to five parts water for extremely heavy grease build-up, such as on the floor and on equipment around deep-fryers. Spray on, let set for a few minutes and rinse or wipe off. For extremely soiled areas, gentle agitation, followed by a soaking period, will result in more thorough cleaning. DON'T be afraid to experiment with Formula G-510EF because it contains no phosphates, nitrates, enzymes, sulfates, suffocates or silicates.

Recommended Detergent – Cont.

Limited Warranty

2010 Products, Inc. warrants that Formula G-510EF will not cause cleansing agent damage to the rubber and synthetic parts of the injection pump (“O” rings, diaphragms, washers, tubing, and other such parts) used with The Gaylord ventilator, Heat Reclaim Unit, or Pollution Control Equipment. 2010 Products, Inc. obligation under this warranty and any warranties implied by law shall be limited to repairing or replacing, at its option, any of said parts which 2010 Products, Inc. examination shall disclose to its satisfaction to have been damaged by the use of Formula G-510EF for the life of the detergent pumping system. This warranty shall not cover damages caused by any other detergent. The use of any other detergent shall void this warranty. All repairs and replacement parts under this warranty shall be F.O.B. 2010 Products, Inc. The owner shall pay the necessary freight and delivery charges; also, removal and installation costs. Any federal, state or local taxes are also extra. Requests for repairs or replacement part should be made to 2010 Products, Inc., P.O. Box 7609, Salem, Oregon, 97303. This is the sole warranty with respect to FORMULA G-510EF.

2010 Products, Inc. MAKES NO OTHER WARRANTY OF ANY KIND WHATSOEVER, EXPRESSED OR IMPLIED, AND ALL IMPLIED WARRANTIES OF MERCHANTABILITY AND FITNESS FOR A PARTICULAR PURPOSE WHICH EXCEED THE AFORESAID OBLIGATION ARE HEREBY DISCLAIMED AND EXCLUDED FROM THIS AGREEMENT. 2010 Products, Inc. SHALL NOT BE RESPONSIBLE FOR INCIDENTAL OR CONSEQUENTIAL DAMAGES RESULTING FROM A BREACH OF THIS WARRANTY.

IMPORTANT

If a cleansing agent other than Formula G-510EF is used with The Gaylord ventilator injection pump and solenoid valves, it is recommended that a warranty similar to the above be obtained from the manufacturer of said product and that the detergent has foaming properties similar to Formula G-510EF.

Formula G-510EF Distributor

For the name and address of the nearest Formula G-510EF distributor contact:

Gaylord Industries
10900 SW Avery Street
Tualatin, OR 97062

E-mail: info@gaylordventilation.com
Website: www.gaylordventilation.com
Phone: 503-783-0924

Gaylord Part Number:

Formula G-510EF GPN 23425 GL-G510EF 20L (5 Gallons)

Recommended Odor Catalyst

Overview

For the spray odor system to work correctly the system must be supplied with a supplemental chemical solution. Formula GS-710E is the only odor catalyst recommended by Gaylord Industries for use in the Gaylord Eliminator hood systems. This solution is delivered directly into the exhaust stream through plenum mounted atomizing nozzles located just behind the hood's particulate separators. The catalyst works in conjunction with the UVC system to break down odor carrying particulate, and mask unwanted cooking odors. The use of GS-710E in combination with the UVC and supplemental odor sections is highly effective at removing commercial kitchen odor emissions. For information of the nearest Formula GS-710E distributor, contact Gaylord Industries or find a local Certified Service agent at www.gaylordventilation.com.



Figure 4- 8-1 GS-710E

Gaylord Formula GS-710E Part Numbers

23404	GL-GS710E-1 (1 Gallon x4)
23406	GL-GS710E-2.5x2 (2.5 Gallon x2)
23405	GL-GS710E-5 (5 Gallon)
23397	GL-GS710E-30 (30 Gallon)
23398	GL-GS710E-55 (55 Gallon)

Setting the Cell Power Pack Voltage

Caution: High voltage present. Only properly trained and certified individuals from Gaylord Industries can make adjustments to the high-voltage power supply utilized to raise or lower the ESP Cell's ionizer and collector voltages.

Acceptable ranges for the voltage on a clean cell are from 13.0 kV to 14.5 kV. Values below 13.0 kV will not remove smoke appropriately and the cell should be removed to review insulator, collector plate, or ionizer wire damage. Consult the Allanson HVPS manual for specific details on the Eliminator High Voltage Power Supply.

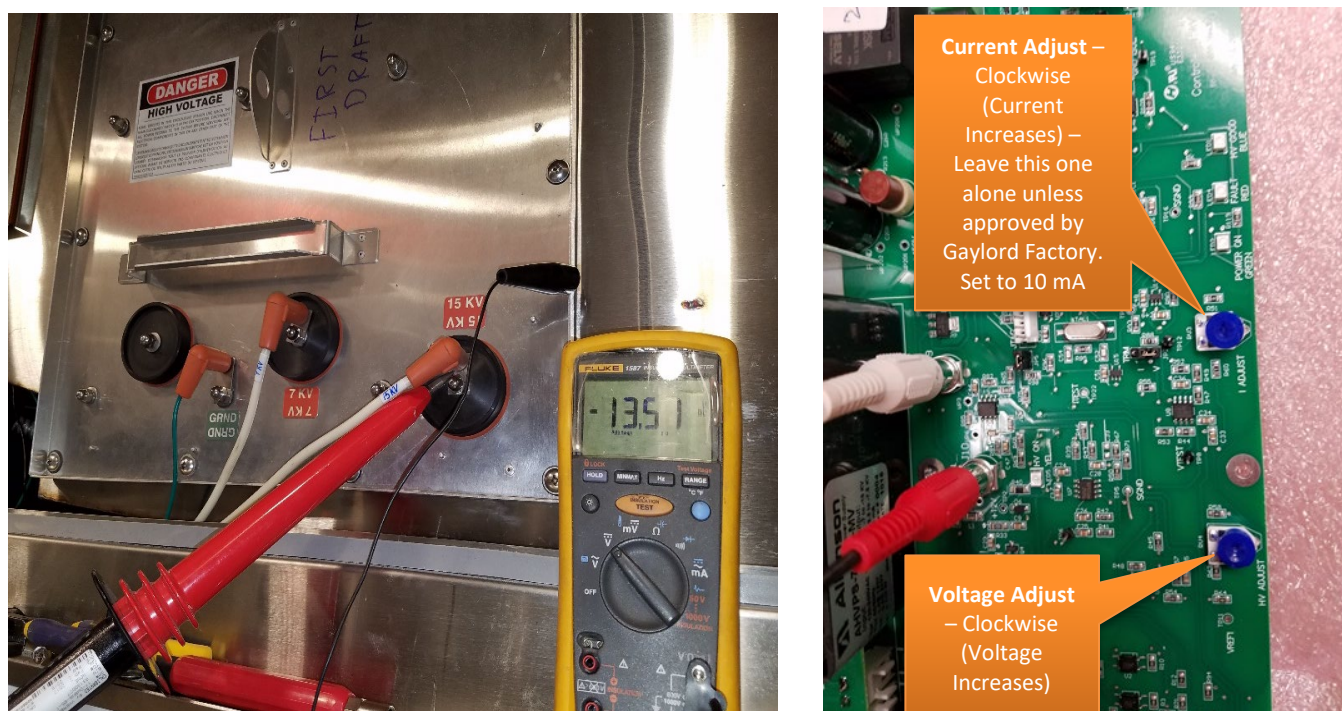

Figure 4-9-1,2 Setting the ESP cell Voltage

Instructions (Setting ESP Cell Voltage):

1. Remove High-Voltage power supply cover. Locate the "I" and "V" adjustments as shown above
2. Utilizing your voltage meter and Fluke 80k-40 high voltage probe, press the Plunger Safety Switch, shown in figure 2-12-1 to get a voltage. **CAUTION High Voltage.** Confirm meter is grounded to cell as shown.
3. If values are between 13.5 to 14.5 kV, system is good. Re-install the high-voltage power supply enclosure lid.
4. If the value is not within 13.5 to 14.5 kV, adjust the voltage knob on the high-voltage power supply CW to increase the voltage. If shorting occurs, remove cell and clear the short. If the unit does not achieve the required voltage with no shorting, increase the voltage all the way CW until it stops then adjust the current knob CW until you achieve at least 13.5 kV. Note: Brand new cells are acceptable at 13.0 kV, voltage will increase as they are loaded.

Setting the EMX Opacity Sensor

The EMX Sensor is utilized to jump the UV lamps to 100% and start a short period of aggressive spray of the catalyst into the Eliminator hood's plenum to address odor. The sensor has an emitter and collector which are positioned inside the hood's canopy. Once the light generated by the emitter is 35% impugned, (*Standard factory setting*), the system will kick off the aggressive response to get ahead of the odor. On systems incorporating AirVantage the ventilation rate will also jump to 100%. Systems utilizing DCA will already be at 100%. See the EMX manual for details on operation and programming.

The unit is designed to have an adjustable activation point which is factory set to 65. This value has overall been the best fit for applications to date taking into consideration the dirtying of the glass cover and the density of the cooking emissions inside a standard hood.

If the hood needs to be more or less reactive you will do the following:

- Increase the number to no more than 80 if you would like it to be more reactive.
- Decrease the number to no lower than 40 if you would like it to be less reactive.

Factory Programming is below in figure 4-11-1



Figure 4-10-1 EMX Sensor

EMX Opacity Sensor - AirVantage Programming - 12/28/17

Setup Procedure:

- 1 **Program EMX** Generation 1 sensor as indicated below.
- 2 Press and Hold "P/-" for 3 seconds until programming menu appears. "Threshold Value will be displayed". Use "T/+" to make selections. "P/-" to go through selections. Press and Hold "P/-" for 3 seconds to exit the program mode.
- 3 **Confirm Program** - Exit Program menu, Press "P/-" for 3 seconds, actual value for the sensor will appear. Re-enter and scroll program to confirm entries
- 4 **Hood Mounting** - Mount Sensors facing each other. Manually adjust Emitter (*Side emitting green light with no programming functionality*) while under power to point the Green light at the collector. Opacity values will go to 99 once you have hit your target. Place glass over the emitter side, secure in place. Next adjust "Blue" pot located at the top of the terminal block while alternating the glass into place to reach just below the 99 output threshold. Repeat till "98 to 99" appear in the display with both pieces of glass present. Process will need to be done for each hood section to account for glass transmittance and canopy length. Secure both sensors in place so they will not be dislodged during shipping.

#	Item	Appearing	Description	Set to
0			Power up sensor..	
0.1	Operational mode	Opacity Value (0-99)	Should display "0" when not aligned or Blocked (Emitter to collector). "99" when aligned and set properly.	n/a
1	Threshold	Current Opacity Setting	Used to set activation level. 99 - Clear, 0 - Blocked	(65)
2	LED Intensity Level (U)	(U2)	Sets intensity level of the Green output on Emitter. <i>Not Used</i>	(U2)
3	Hysteresis Level	(H0)	Deadband. Options H0 to H9	(H6)
4	Discrete Output	(nc)	Sets the relay output.	(nc)
5	Extend Output Pulse	(P0)	Reduces relay chatter. In 1/100 seconds	(P9)
6	Null Offset (nu)	(nu)	<i>Not Used</i>	(nu)

Figure 4-10-1 Factory Setting the EMX Opacity Sensor

For greater detail on the wiring and setting of the EMX sensor, see the EMX sensor Tech Manual.



ILLUMINATION ADJUSTMENT
CW to INCREASE

DESCRIPTION	WIRE COLORS
TX -	BLACK
TX+	RED
Shield	GREEN
Discrete (NPN/PNP) output	WHITE
0-5V Analog output	RED
Power -	BLUE
Power +	BROWN

RECEIVER CONNECTIONS



DESCRIPTION	WIRE COLORS
TX+	RED
TX -	BLACK

TRANSMITTER CONNECTIONS

Troubleshooting

Using the Troubleshooting Charts

The following Troubleshooting Charts are designed to easily find common problems, the probable cause and guidance on corrective action. In some cases, the Corrective Action column will reference the Testing and Repair section of this manual for additional guidance and actions.

SMOKE LOSS		
SYMPTOM	PROBABLE CAUSE	CORRECTIVE ACTION
1. The Ventilator is not exhausting all the smoke, heat and grease properly	A. Exhaust volume is low due to fan performance issues, belt break, or a balancing damper not adjusted properly.	1. Confirm hood was properly commissioned achieving design airflows and capture and contain directly after installation
		2. Check exhaust fan for broken or slipping belts. Adjust or replace belts as required.
		3. Confirm proper rotation of fan wheel.
		4. Check for proper size of exhaust fan. Fan must deliver Ventilator Nameplate rating or greater.
		5. Check and adjust Gaylord Balancing Damper as described on pages 2-19 of this manual.
		6. Check for open access panel in duct system and close or re-install if open.
	B. Exhaust volume is low due to a heavy grease accumulation on the Extractors.	1. Remove the Extractors and inspect for grease accumulation. If the extractors are not being washed effectively refer to the Troubleshooting section WASH SYSTEM - PLENUM & EXTRACTOR WASH. Wash Extractors in commercial dish machine, reinstall in hood.
		2. Remove and wash secondary filters behind wash door
		3. Examine Flow Straightener and Cell for clogging or obstructions. Remove/clean as required.
C. Hood ducting is improperly designed, fabricated, or connected to an adjacent duct system.	1. Inspect the duct system and verify there are no non-Type I Ventilator systems tied in. If so they must be removed.	

Troubleshooting – Cont.

SMOKE LOSS		
SYMPTOM	PROBABLE CAUSE	CORRECTIVE ACTION
	D. Improperly placed make-up air diffusers.	1. Make-up air directed at the Ventilator will likely create cross drafts disrupting the airflow into the Ventilator. Adjust the louvers to direct the make-up air away from the Ventilator. Note: ASHRAE 154 States that any replacement air source shall not produce greater than 50 FPM velocities at the hood's bottom lower edge. Gaylord's PBW is the only exception to this requirement. Refer to page 5-5 for guidance.
		2. Make-up air must be delivered through non-aspirating registers at low velocity, distributed evenly throughout the kitchen area. Refer to page 5-5, or the Gaylord Capture Performance Guarantee for guidance.
		3. Make-up air registers located near the Ventilator shall have all louvers directed away from the Ventilator. Directing or forcing the make-up air at the Ventilator typically creates cross drafts resulting in smoke loss. Refer to page 5-5 for guidance.
	E. Inadequate make-up air	1. Make-up air must be supplied for replacement of air exhausted through all kitchen exhaust systems. Refer to page 5-5 for guidance.
		2. A general "rule of thumb" is that 60% of the replacement air should be fresh, lightly tempered air brought into the kitchen area, with the remaining 40% allowed to flow into the kitchen from adjacent areas.
	F. Exhaust fan discharge	1. There should be no screen over the discharge. If one is found, it should be removed.
2. The direction of discharge should not be into the prevailing winds nor downward onto the roof. A vertical discharge is highly recommended.		

Troubleshooting – Cont.

EXHAUST FAN		
SYMPTOM	PROBABLE CAUSE	CORRECTIVE ACTION
1. If the START FAN button is pushed but the exhaust fan does not come on.	A. If C-7000-SPC/DCA controlled, overload protector on the magnetic starter has tripped.	1. Push the "Reset" button on the magnetic starter and push the START FAN button.
	B. If a HOA (Hand Off/Automatic) type magnetic starter switch is used, the selector switch may have been moved from the automatic position.	1. Check the switch and turn the selector to the automatic position.
	C. Exhaust fan circuit breaker tripped.	1. Investigate possible sources to trip the breaker. Reset circuit breaker.
	D. If the system is equipped with a fused disconnect switch for the exhaust fan, a fuse or fuses may have blown out.	1. Check continuity of fuses and replace if necessary. Investigate sources for the blown fuse(s).
	E. The Gaylord Command Center may have been improperly wired.	1. Refer to project wiring diagrams
	F. The Gaylord Command Center is malfunctioning.	1. Refer to the Operation and Maintenance Manual for the Gaylord Command Center, GPC-7000 SPC Troubleshooting section.
	G. Local disconnect was deactivated while cleaning was conducted. Cleaner failed to reconnect.	1. Locate and reconnect disconnect.
	H. For AirVantage Systems, VFD in error or overload condition.	1. Consult the VFD technical manual for details. Determine source of failure and correct as necessary.
2. If the START FAN button is pushed and air is not being pulled through the Ventilator, but you can hear the fan running.	A. Closed or blocked balancing damper in the hood exhaust collar.	1. Check the balancing damper. Adjust as necessary to achieve design airflow.
	B. Fan drive belt is slipping.	1. Tighten belt and then measure exhaust volume to verify design airflow is being achieved.
	C. Fan is running in reverse.	1. Contact electrical contractor to wire correctly.

Troubleshooting – Cont.

WASH SYSTEM - PLENUM & EXTRACTOR WASH		
SYMPTOM	PROBABLE CAUSE	CORRECTIVE ACTION
1 The Wash Cycle is not adequately cleaning the Extractors or Plenum.	A. The water supply is turned off or partially off.	1. Check the hand valves inside the Wash Control Cabinet to make sure they are fully opened. 2. Check any valves upstream of the Wash Control Cabinet to confirm they are fully opened.
	B. Low Water Pressure - Check the water pressure gauge inside the Command Center cabinet. Pressure should be 40 psi minimum while the Ventilators are washing.	1. Check the hand valves inside the Wash Control Cabinet to make sure they are fully opened. 2. Check any valves upstream of the Wash Control Cabinet to make sure they are fully opened.
		3. The Line Strainer inside the Wash Control Cabinet may be clogged. Refer to the Operation, Maintenance and Installation Manual for the Gaylord Command Center and Wash Control Cabinet for instructions on cleaning the Line Strainer.
		C. Low Water Temperature - Check the temperature gauge inside the Wash Control Cabinet. The temperature should be between 140 and 180 degrees F prior to the Hubble Inline heater. 160 to 180F after Hubbell Heater.
	D. Inadequate Wash Cycle frequency.	1. Refer to Chapter 4 for guidance. Determine proper duty and program C-7000 Controller
	E. Inadequate length of Wash Cycle.	1. Refer to Chapter 4 for guidance. Increase Wash Cycle length as necessary.
	F. Detergent tank empty.	1. Check and fill the detergent tank at least weekly.
	G. Improper detergent.	1. Refer to Chapter 4 for recommended detergent.
H. Detergent pump has lost its prime or is malfunctioning.	1. Refer to the Operation, Maintenance and Installation Manual for the Gaylord Command Center and Wash Control Cabinet, the Troubleshooting section.	

Troubleshooting – Cont.

WASH SYSTEM - PLENUM & EXTRACTOR WASH		
SYMPTOM	PROBABLE CAUSE	CORRECTIVE ACTION
	I. Clogged spray nozzle(s).	1. To determine if there are clogged spray nozzles start test wash with access panels partially open to see nozzle without spray. Service nozzles as needed.
2. Plenum Wash or Extractor Wash fails to come ON when programmed to do so.	A. Malfunctioning water solenoid valve located on top of the Ventilator.	1. Refer to page 5-23 for trouble shooting and corrective action.
	B. Malfunctioning PLC control in the GPC-7000 SPC Command Center.	1. Refer to the Operation, Maintenance and Installation Manual for the Gaylord Command Center and Wash Control Cabinet (C-7000A Technical Manual), the Troubleshooting section.
	C. Fan does not shut OFF. Hot equipment or improperly set program temperatures for the DCA or AirVantage System can prevent the Plenum wash from occurring. <i>(DCA only will display "AutoStart due to High Temperature in Hoods")</i>	1. Confirm the equipment is shut down after daily operations. Deactivate ALL equipment. Monitor results. 2. Consult DCA or AirVantage technical manual to confirm the proper set points are being applied. On AirVantage - AutoSTOP and Dead band setting are possible solutions. On both AirVantage and DCA increasing the TL setting will allow system to shutdown at a higher inactive temperature.
3. Plenum Wash activates while exhaust fan is running	A. Motor starter, VFD, or other device is manually activating the exhaust fan.	1. Locate source of manual fan activation on VFD or motor starter and place back in automatic.
4. Extractor Wash or Plenum Wash is spraying when the Command Center is <u>not</u> in a Wash Cycle	A. Solenoid valve is stuck open due to debris or other obstruction.	1. Gently tap the valve housing with a hammer. This should release foreign material trapped in the valve and the water should stop. If tapping does not release the valve must be disassembled and checked.
		2. Replace solenoid if operation cannot be restored.

Troubleshooting – Cont.

DRAINS		
SYMPTOM	PROBABLE CAUSE	CORRECTIVE ACTION
1. During a Wash Cycle water overflows the gutter and comes out the inlet slot.	A. Clogged drain outlet. (Note: each Ventilator section has its own drain outlet).	1. The drain outlet is always located at either the right or left end of the Ventilator. Open the Extractor Access Door at both ends of the Ventilator. Reach in and down into the bottom of the Grease Gutter until the drain outlet is found. Remove any grease, debris, or obstruction found.
1. During a Wash Cycle water overflows the gutter and comes out the inlet slot.	A. Clogged drain outlet. (Note: each Ventilator section has its own drain outlet).	1. The drain outlet is always located at either the right or left end of the Ventilator. Open the Extractor Access Door at both ends of the Ventilator. Reach in and down into the bottom of the Grease Gutter until the drain outlet is found. Remove any grease, debris, or obstruction found.
	B. If more than one Ventilator section is not draining, it indicates that the building drain system is clogged.	1. A chemical drain cleaner applied per instructions may dissolve stoppage. Pour cleaner into the Grease Gutter at the drain opening. 2. Hire a drain roter service to clear the entire drain system.
	C. Clogged or full grease trap.	1. Some cities and counties have codes which require grease traps. If a grease trap is in use, check to ensure that it is not clogged.
2. Water runs out over the top of the drain line or through the Front Panel LED Chase.	A. The ESP Sump is leaking	1. Open front panel and verify the ESP Cell, flow straightener, and access covers are properly installed. Confirm all gaskets are in good working order and properly installed. Correct as necessary and remove any standing water discovered in the enclosure.
	B. Sump Drain Line is clogged.	1. Remove cell and clear line between the sump and the extractor gutter. Confirm Pre-Flush tube is properly operating. Confirm the Pre-Flush is directed at the ball valve.
	C. Wash Manifolds are leaking	1. Verify the 4-inch drain space does not have one or more wash manifolds leaking or improperly installed.

Troubleshooting – Cont.

UV SYSTEM		
SYMPTOM	PROBABLE CAUSE	CORRECTIVE ACTION
1. After exhaust fan is started and the UV Status lights on the Ventilator section(s) illuminate as follows: Green light is Off Yellow light is Off Blue light is On Green Front Panel ESP Light is On	A. XGS Extractor is missing.	1. Find and replace missing XGS Extractor.
	B. Extractor Access Door open.	1. Close Access Door.
	C. UV Module Access Door missing or partially open.	1. Replace or close panel.
	D. Safety Interlock Pressure Switches) are out of adjustment.	1. Refer to Setting UV Pressure Switch Instructions on page 3-6.
	E. Airflow is too low.	1. Confirm Ventilator is at design exhaust volume. Refer to instructions beginning on page 6-1 for measuring exhaust volume.
	F. The internal temperature of the Ballast Box has exceeded 118° F. and the High Temperature Shutdown Controller has activated.	1. Confirm that the cooling fan has not failed. If failed, remove and replace as necessary.
		2. Check the removable filter in front of the Ballast Box Ventilation Fan to see that it is not clogged or that air inlet to the fan or the louvers at the air outlet is not blocked by building insulation or any other material. Clean the filter or replace with a new filter and/or remove the material that is blocking the air inlet or outlet
3. Building insulation has been placed over the top of the Ballast Box. Corrective action: Cut a rectangular opening in the insulation, the size of the Ballast Box, and slide it down around the sides of the box. Tape the insulation down so it will not interfere with the openings. Note: the ELXC-SPC Ventilator has been approved and listed for such application and must not be covered with insulation impeding the cooling openings going into the Ballast Box.		
	4. Ballast Box Access Cover Plate gasket is missing or broken down. Remove old gasket and replace. Refer to the Parts section of this manual to order a new gasket.	

Troubleshooting – Cont.

UV SYSTEM - Cont.		
SYMPTOM	PROBABLE CAUSE	CORRECTIVE ACTION
		5. The cooking equipment under the Ventilator is in a "runaway" condition operating too hot. Check with owner to see if cooking equipment is operating properly.
2. After exhaust fan is started and the UV Status lights on the Ventilator section(s) illuminate as follows: Green light is On . Yellow light is On . Blue light is Off .	A. One or more UV Lamps has failed	1. Refer to page 6-7 for instructions on determining which Lamp has failed and replace.
	B. UV Ballast has failed.	1. Refer to page 6-7 for instructions on determining which Ballast has failed and replacing.
	C. Loose wires.	1. Check wires 1A and 3A from the Command Center to the UV Ballast Box. If either are loose, re-secure and tighten.
3. After exhaust fan is started and the UV Status lights on the Ventilator section(s) illuminate as follows: Green light is Off . Yellow light is On . Blue light is Off .	A. 200 VAC electrical Service to the UV Ballast Box located on the top of each Ventilator section is off.	1. Take steps necessary to supply power to each UV Ballast Box. Check electrical service panel for deactivated circuit breaker.
	C. Loose wire at the Command Center or UV Ballast Box.	1. Check terminal 1U from UV Ballast Box back to the Command Center.
	D. Green status light miss-wired or failed.	1. Blown Green Status light. Confirm status light is getting power and/or replace lamp as necessary.
4 After the exhaust fan is started the UV Status Lights on the Ventilator sections do not illuminate.	A. Hood in Drying Cycle	1. At the completion of Plenum and Cell washes the exhaust fan will run for 1 hour prior to activating the ESP and the UV system. This is intended to reduce arcing due to a wet ESP cell. Yellow light on time delay relay located in the C-7000-SPC Command Center will be lit during this time period.
	B. No power on terminal 6P in the Command Center.	1. Check and replace the fuse FU20 located in the Command Center. Confirm 6P is not shorted and the reason the fuse is blown. If 6P is shorted at some point, find the pinch or short and repair as needed.

Troubleshooting – Cont.

UV SYSTEM - Cont.		
SYMPTOM	PROBABLE CAUSE	CORRECTIVE ACTION
	C. Loose wire.	1. Check for 120VAC between 6P and 5U. Re-secure any loose connections between the Ventilator and the Command Center
5. Repeated Ballast/UV Lamp failures.	A. UV Ballast Box located on the top of the Ventilator is too hot.	1. Confirm PUV Enclosure has proper ventilation and cooling fan is operating free from obstructions. 2. Confirm cooling fan is operating properly. If the unit has failed, remove and replace with new PUV cooling fan. 3. Check removable filter. Shake out and replace.
	B. Cooling fan opening, and vents are covered up with insulation.	1. Remove all obstructions from the inlet to the fan and the exit vents. Access to the top of the Ventilator will be required. Note: the ELXC-UV Ventilator has been tested and listed for such application and must not be covered with insulation impeding the cooling openings going into the Ballast box.
	C. Ballast Box Access Cover Plate gasket is missing or has broken down.	1. Remove old gasket and replace. Refer to the Parts section of this manual to order a new gasket.
6. Command Center not functioning as intended.	A. Varies.	1. Refer to Operation, Maintenance and Installation Manual for the Gaylord Command Center and Wash Control Cabinet, the Troubleshooting section. Symptom will be NO power on 6P from the C-7000-SPC Command Center.

Troubleshooting – Cont.

ESP (SMOKE REMOVAL SECTION)		
SYMPTOM	PROBABLE CAUSE	CORRECTIVE ACTION
1. Smoke is not being removed from the exhaust airflow.	1. High Voltage Power Supply not operating. GREEN Light on Front of Hood is Off	1. Check 6P fuse (FU20) at the C-7000 SPC Command Center. 10 Amp Fuse may have blown
		2. Verify both C-7000-SPC and (if applicable) AirVantage Command Centers are powered and indicate fan is in operation.
		3. Verify the ESP Section Door Switch is closed. Remove Cell Panel, and Press Plunger Switch. If cell activates, adjust Plunger Safety Switch rod length, or confirm ESP access panel is properly latched. CAUTION: HIGH VOLTAGE!
		4. UV Pressure switches not closed. See UV Section to reset the UV pressure switches. Page 3-6.
		5. Verify leads are properly connected to the ESP Cell and that there is power on 6R behind the Power pack enclosure lid, (<i>Located under the Cross Over Duct</i>). If there is no power on the unit refer to Section 8 ESP to trace fault back to the PUV Ballast Box. CAUTION: HIGH VOLTAGE!
	2. Cell high voltage wires disconnected.	Reconnect the high voltage wires.
3. Cell shorted internally producing a "Clicking" noise. GREEN Light on front of Hood goes ON and OFF		1. Cell Wet. Symptom will be repetitive or continuous arcing. Wait for 1 hour and recheck
		2. Cell Ionizer wire has broken. Remove Cell and replace ionizer wire. Inspect cell for additional shorts. Use voltmeter to check for continuity between ionizer and collector terminals and the cell body. They should show an "OPEN". CAUTION: HIGH VOLTAGE!
		3. Cell dirty and in need of service. Remove and clean in a deep well sink or other dedicated washing device. DO NOT use high pressure wash.

Troubleshooting – Cont.

ESP (SMOKE REMOVAL SECTION) Cont.		
SYMPTOM	PROBABLE CAUSE	CORRECTIVE ACTION
	4. Power Pack voltage output too low. GREEN Light on Front Panel is ON	<p>1. Automatic voltage adjustment is low due to a dirty, wet, or damaged cell. Inspect cell for missing or damaged Ionizer wires. Repair/Clean/Replace as needed. Confirm with voltmeter.</p> <p>2. Test Power Pack output on the ESP Cell with a High Voltage Probe. 13.5 kV on the ionizer and 6.0 kV or greater. Remove terminals with POWER OFF. Test High Voltage Boot ends with High Voltage Probe. Confirm the leads are 13.5 kV to 15 kV. If voltage is out of range, contact Gaylord Service Department for assistance. Power supply maybe out of adjustment. Consult Allanson Power supply manual.</p>
	5. Ionizer wire(s) missing. GREEN Light on Front Panel ON	Remove ESP Cell and inspect for missing Ionizer wires. Replace and reinstall. Contact Gaylord/ Parts Town for Ionizer wire replacements.

ODOR ABATEMENT		
SYMPTOM	PROBABLE CAUSE	CORRECTIVE ACTION
1. Odor not being sufficiently removed	1. UV System not operating	1. See UV corrective actions. Yellow or Blue Standby lights activated.
	2. AVHC is unpowered. Heartbeat LED on AVHC control board will be off.	1. Verify 120V across L1 and L2. If no power check supply breaker. If powered proceed to Step 2.
		2. Verify 24 VAC to control board. If there is power, then replace control board. If unpowered proceed to Step 3
		3. Check continuity on 120V fuse. If fuse is bad, replace it. If fuse is good, then replace 24 VAC transformer.

Troubleshooting – Cont.

ODOR ABATEMENT Cont.		
SYMPTOM	PROBABLE CAUSE	CORRECTIVE ACTION
	3. DCA is unpowered. Heartbeat LED on control board will be off.	1. Verify 120V across L and N. If no power check supply breaker. If powered proceed to Step 2.
		2. Verify 12 VDC to control board. If there is power, then replace control board. If unpowered proceed to Step 3
		3. Check continuity on fuse FU1. If fuse is bad, replace it. If fuse is good, then replace 12V VDC power supply.
	4. Catalyst Nozzle Clogged	1. Open UV Module access door. Remove module if needed. Remove atomizing nozzle and clear clog.
	5. Out of Catalyst	1. Verify Chemical Pump operation at GPC-7000 SPC. Use test switch to induce a flow. Observe chemical being added. Re-prime pump as needed.
		2. Check Chemical container/drum for the presence of chemical. Replace and prime pump as needed
	6. Catalyst output low	1. Adjust output cam on the Chemical Pump in the GPC-7000 SPC Command Center to desired level. Verify the output is satisfactory at the system's exhaust outlet. See page 4-4 for details.

Measuring Airflow

Overview

ELXC ventilators are factory engineered to operate at a specific exhaust volume, CFM (Cubic Feet per Minute), based primarily on the type of cooking appliance, their associated energy input, and the exact model of the ventilator. Smoke capture, grease extraction efficiency, and heat removal are dependent upon the proper exhaust volume (airflow) through the ventilator. If the exhaust volume is below designed levels, smoke, grease and heat may escape the confines of the ventilator creating an uncomfortable kitchen for the operator. It will also reduce grease extraction efficiency of the XGS extractors resulting in additional grease depositing in the duct system and exhaust fan. This can lead to sanitation problems and fire hazards if left uncorrected. If the exhaust volume is higher than design, more energy will be used to operate the exhaust fan, excessive noise levels may result, and grease can be pulled through the extractors depositing in the duct and fan. Operating at higher or lower airflows than design will result in the entire kitchen ventilation system being out of balance.

It is important that at initial installation of the ventilator the exhaust volume is measured to verify that it meets design. It is also recommended that the exhaust volume be measured once every two or three years to ensure that the exhaust fan is operating properly. The exhaust volume for each ventilator section is stamped on the ventilator nameplate (refer to Figure 6-4-1).

Measuring Airflow

The ventilator exhaust volume is determined by measuring the air inlet velocity and using FPM to CFM Table 6-4-1 to convert the recorded velocity FPM, to an exhaust volume in CFM Per Lineal Ft. of ventilator. This method requires an Anemometer and the recommended unit is a Pacer 2 3/4" Rotating Vane Model DA40 or DA4000 Digital Anemometer. These instruments can be purchased from Gaylord Industries. To measure the air inlet velocity and confirm the exhaust volume, proceed as follows:

Instructions

1. For safety purposes turn off the cooking equipment and allow cooling.
2. Confirm that all XGS extractors are clean and in place.
3. Close all extractor access doors.
4. Make sure all UV Module access doors are in closed and latched.
5. Turn on the exhaust and makeup air fan(s).
6. Attach the cable from the sensing head to the meter (refer to Figure 6-3-2).
7. Attach the handle sections to the sensing head.
8. Beginning at one end of the ventilator, place the sensing head into the inlet slot with the handle in the horizontal position as shown in Figure 6-3-1.
9. Using the 16 second averaging feature on the meter, slide the sensing head along the entire length of the slot, slowly, at a rate that would last approximately 16 seconds. If you reach the end of the air inlet slot before the 16 second interval has elapsed, continue moving the probe head back the other direction (without removing it) until the 16 second interval has expired. At the end of 16 seconds an average velocity will appear on digital readout of the meter.
10. Record the average velocity (FPM).
11. Repeat the process for any additional ventilator sections.
12. Using Table 6-4-1, find the nearest inlet velocity to the recorded velocity and read across to the related CFM Per Lineal Ft. column. This is called the Determined CFM Per Lin. Ft.
13. Measure the length of the ventilator, in feet, and multiply by the Determined CFM Per Lin. Ft. The result is the Total Exhaust Volume for the ventilator.
14. Compare this Total Exhaust with the "Min. Suggested Total Exhaust Volume for This Section" stamped on the ventilator nameplate and proceed to step 17 (Refer to Figure 6-4-1).

15. The acceptable range is 0% low to 10% high. If the CFM is not within acceptable range, then corrective action must be taken to bring the exhaust volume within design.
16. If the ventilator does not include a balancing damper, the exhaust volume must be increased or decreased by adjusting the exhaust fan. If the exhaust fan is not operating properly, refer to the trouble shooting section of this manual for possible problems and corrective action.
17. If the ventilator has a balancing damper, and if the Determined CFM is low, the balancing damper needs to be opened slightly. If the Determined CFM is high the balancing damper needs to be closed slightly. Place the sensing head at the air inlet slot and continue either opening or closing the balancing damper until the velocity reading on the meter is at or close to the desired inlet slot FPM number on Table T-6-4-1.



*Figure 6-3-1 2 3/4" Rotating Vane Anemometer
Sensing Head at Air Inlet Slot*



Figure 6-3-2 Anemometer



HOTTE D'ASPIRATION SANS REGISTRE DE TIRAGE

CETTE HOTTE NE PEUT PAS ÊTRE UTILISÉE SANS UN SOUS-ENSEMBLE COMPRENANT UNE ARMOIRE DE COMMANDE RÉPERTORIÉE, MODÈLE GPC-7000-SPC.

CETTE HOTTE D'ASPIRATION A ÉTÉ CERTIFIÉE SELON LES NORMES UL 710 "HOTTES D'ASPIRATION POUR L'ÉQUIPEMENT DE CUISSON COMMERCIAL", UL 710C "LAMPES À RAYONS UV SERVANT À LA RÉDUCTION DES VAPEURS GRASSES ÉMISES PAR L'ÉQUIPEMENT DE CUISSON, ET UL 867 "ÉPURATEURS D'AIR PAR ÉLECTROSTATIQUE".

CERTIFIÉE POUR UTILISATION À DÉGAGEMENT ZÉRO DES MATÉRIAUX COMBUSTIBLES À L'AVANT, À L'ARRIÈRE, ET SUR LES CÔTÉS, AINSI QU'AUTOUR DE L'ENCEINTE ÉLECTRIQUE UV SI CONSTRUITE SELON LES DÉTAILS DU RAPPORT DE CERTIFICATION DU MANUFACTURIER.

CETTE HOTTE RÉPOND À TOUTES LES EXIGENCES DE L'ÉDITION LA PLUS RÉCENTE DE LA NORME NFPA-96 ET IMC (CODE INTERNATIONAL DE MÉCANIQUE).

LES INDUSTRIES GAYLORD
10900 S.W. AVERY STREET
TUALATIN, OR 97062 USA
(800) 547-9696

COURRIEL : info@gaylordventilation.com
www.gaylordventilation.com
BREVET EN INSTANCE

ELXC-SPC040617 / 23506

DONNÉES D'INGÉNIERIE

N° DE MODÈLE	ELXC-SPC-
N° DE SÉRIE	
1. VOLUME MINIMAL D'ASPIRATION TOTALE SUGGÉRÉ POUR CETTE SECTION	PI ³ /MIN
2. PRESSION STATIQUE D'ASPIRATION AU COLLET D'ÉCHAPPEMENT	2,00 CE

TEMPÉRATURE MAX. DE LA SURFACE DE CUISSON	SERVICE LÉGER	400°F (205°C)	600°F (315°C)	700°F (370°C)
GAMME ELXC-SPC	VALEURS MINIMALES INDIQUÉES EN PP/MIN PAR PIED DE HOTTE LINÉAIRE			
MONTÉE AU MUR EN DÉBORD AVANT/CÔTÉ, (PO), *AVEC PLEIN PANNEAU LATÉRAL	6 0*-6	6 0*-6	6 0*-6	9 6
MONTÉE AU MUR AVEC MUR DE CAPTURE	100 100	122 131	195 217	252 214
MONTÉE AU MUR / BB GAMME "X"	108 108	132 141	214 234	232 280
ILOT SIMPLE EN DÉBORD, (PO), AVANT, ARRIÈRE & CÔTÉS	12 12	12 12	12 12	S.O.
ILOT SIMPLE HOTTE DE LA GAMME "CL"	-	210	314	S.O.

PRUDENCE - RISQUE DE CHOC ÉLECTRIQUE - IL FAUT PLUS D'UN SECTIONNEUR POUR DÉSACTIVER LE DISPOSITIF AVANT UN ENTRETIEN.

DÉBRANCHER AVANT TOUT ENTRETIEN : GPC-7000 SPC - COMMANDES DE LA HOTTE/LAMPES 120 VOLTS - COURANT ÉLECTRIQUE 120 VOLTS DES LAMPES À UV. CONSULTER LE MANUEL TECHNIQUE DE GAYLORD ET LE SCHÉMA ÉLECTRIQUE C-7000 SPC POUR PLUS DE DÉTAILS.

1. CONSULTER LE MANUEL TECHNIQUE DU VENTILATOR GAYLORD POUR LA OU LES MÉTHODE DE VÉRIFICATION DES VOLUMES D'AIR.
2. AVERTISSEMENT - UN VERROUILLAGE ÉTÉ PRÉVU POUR RÉDUIRE L'EXPOSITION EXCESSIVE AUX RAYONS ULTRAVIOLETS. NE PAS CONTOURNER CE VERROUILLAGE.
3. CONSULTER LE MANUEL TECHNIQUE DU VENTILATOR GAYLORD POUR L'INSTALLER ET L'ENTRETIEN CORRECTEMENT ET POUR DES CONSIGNES DE SÉCURITÉ.
4. À MOINS D'INDICATION CONTRAIRE, LES DÉBORDS SONT DE 6 PO À L'AVANT ET 6 PO LATÉRALEMENT. CEUX DE LA HOTTE EN ILOT "CL" SONT DE 6 PO À L'AVANT ET DE 12 PO LATÉRALEMENT. (VOIR LEUR POSITIONS CI-DESSOUS).
5. S'IL FAUT LES REMPLACER, NE PAS UTILISER D'AUTRES FILTRES PRIMAIRES ET SECONDAIRES QUE CEUX DE GAYLORD.

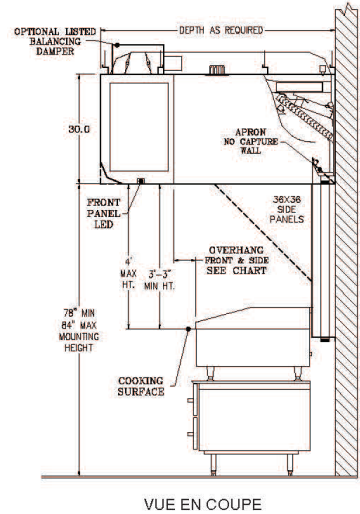

Figure 6-4-1 Listed Minimum Airflows and Overhangs

ELXC-SPC Airflow Table			
FPM to CFM (8/20/2019)			
Inlet Slot (FPM)	Flow Rate (CFM/LF)	Inlet Slot (FPM)2	Flow Rate (CFM/LF)2
300	102	691	235
353	120	735	250
456	155	779	265
500	170	823	280
529	180	956	325
588	200	1020	348
662	225	1080	367

Figure 6-4-2 Eliminator Airflow vs. Average Slot Velocity

Capture Performance

All Gaylord ventilators are factory engineered to operate at a specific exhaust volume, CFM (Cubic Feet per Minute), based primarily on, the type of cooking appliance, and the exact model of the ventilator. Capture performance is based on two primary functions, 1) the ventilator is exhausting the engineered CFM and 2) the make-up air is being introduced correctly. Make-up air introduced incorrectly will typically result in smoke and heat loss into the kitchen, even if the ventilator is operating at the engineered CFM. Make-up air is typically brought into the kitchen space through ceiling diffusers or through a combination of Gaylord Make-Up Air Plenum Boxes, Model PBW, (refer to Figure 6-6-1) and ceiling diffusers.

Gaylord Capture Performance Guarantee

Gaylord Industries warrants the Capture Performance of the ventilator, only if the exhaust air volumes are correct, per the exhaust volume guidelines as stated below, and the make-up air volumes are correct and delivered correctly per the make-up air delivery guidelines as stated below.

Exhaust Volume Guidelines

The amount of exhaust CFM through the ventilator shall be between 100% to 110% of the values stamped on the ventilator nameplate for each ventilator section.

Make-up Air Delivery Guidelines

A. With Gaylord Plenum Boxes and ceiling diffusers.

1. Gaylord Plenum Boxes Model PBW shall be located immediately in front of the ventilator, a minimum of 18" from the lower lip of the ventilator to the discharge surface of the Plenum Box. (Refer to Figure 6-6-1).
2. The amount of make-up air delivered through the Gaylord Plenum Box(s) shall be between 90% and 100% of the values shown on Gaylord Submittal Drawings.
3. The amount of make-up air through the Plenum Boxes shall not exceed 60% of the exhaust volume of the ventilator.
4. Ceiling diffusers shall be at least 6'-0" away from all sides of the ventilator and the outlet velocity at the diffusers shall not exceed 150 Feet per Minute (FPM).

B. With ceiling diffusers only.

1. Ceiling diffusers shall be at least 15'-0" away from all sides of the ventilator and the outlet velocity at the diffusers shall not exceed 300 Feet per Minute (FPM) (Refer to Figure 6-6-1).

C. Additional Requirements.

1. The maximum velocity of the make-up air from diffusers, transfer air diffusers, or any other type of diffusers shall not be greater than 75 FPM on all open sides of the lower edge of the ventilator.
2. Cross drafts from pass through windows, hallways, or other openings shall not exceed 50 FPM.
3. All forms of make-up air, such as ceiling diffusers, transfer air diffusers, and Plenum Boxes must be evenly distributed around each ventilator to prevent unequal pressurization.
4. Kitchen pressurization shall not exceed -0.02" W.G. relative to the dining or adjacent spaces as stated in NFPA-96 and ASHRAE Standard 154.
5. For more information on acceptable methods of make-up air delivery reference ASHRAE Standard 154

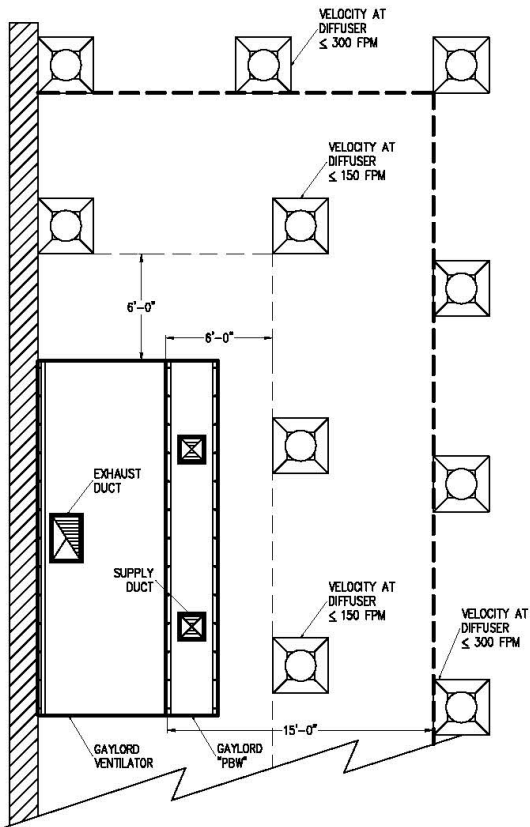

Gaylord Capture Performance Guarantee

Gaylord warrants the Capture Performance of the ventilator, only if the Exhaust Air Volumes are correct, per the Exhaust Air Volume Guidelines, and the Make-up Air Volumes are correct and the make-up air is delivered correctly, per the Make-up Air Delivery Guidelines as stated below.

Exhaust Air Volume Guidelines:

1. The amount of air exhausted by the Gaylord Ventilator shall be between 100% and 110% of the values shown on the Plan View for the Exhaust Ducts for each ventilator

Make-up Air Delivery Guidelines:

1. Gaylord "PBW" Plenum boxes shall be included for each ventilator
2. The amount of make-up air delivered through the Gaylord "PBW" plenum boxes shall be between 90% and 100% of the values shown on the Plan View for the Supply Ducts for each ventilator
3. The make-up air delivered using Gaylord "PBW" plenum boxes shall not exceed 60% of the exhaust volume of the ventilator
4. Ceiling diffusers shall be at least 6'-0" from all sides of the ventilator and the velocity at the diffuser shall not exceed 150 Feet per Minute (FPM)
OR
Ceiling diffusers shall be 15'-0" from all sides of the ventilator and the velocity at the diffuser shall not exceed 300 Feet per Minute (FPM)
5. The maximum velocity of the make-up air from Transfer Air, Diffusers, etc. shall not exceed 75 FPM at the ventilator lip
6. Cross drafts from pass through windows, hallways, or other openings shall not exceed 50 FPM
7. All forms of make-up air introduction (PBW, Transfer Air, Diffusers, etc.) must be evenly distributed around each ventilator to prevent unequal pressurization
8. Kitchen pressurization shall not exceed -0.02"W.G. relative to the dining or adjacent spaces, as stated in NFPA-96 and ASHRAE Standard 154
9. For more information on acceptable methods of Make-up Air Delivery reference ASHRAE Standard 154.

Following these guidelines will result in proper capture and containment at the ventilator and enact the Gaylord Capture Performance Guarantee. If jobsite conditions cannot accommodate these guidelines, consult factory for alternative design.

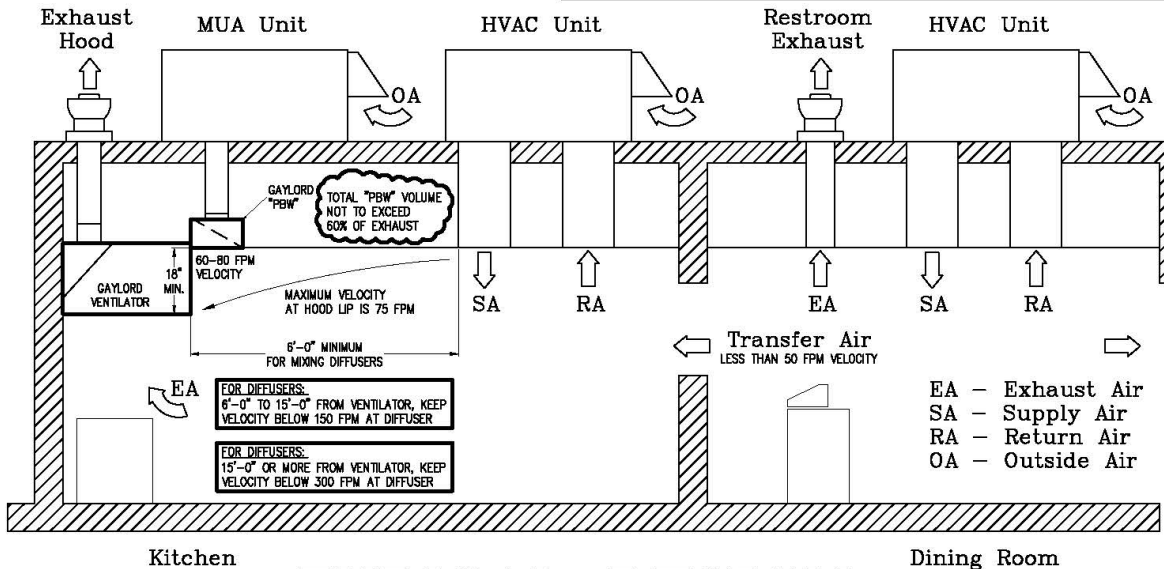

TYPICAL DESIGN

Figure 56-6-1 Capture Performance Guarantee

Overview

The UV lamp modules come in a single 5' length. Each UV module will correspond to one exhaust collar.

Replacing UV Lamps

DANGER: Replacing UV Lamps as outlined on this page **MUST** be performed by a Gaylord Certified Service Agent. For a list of Gaylord Certified Service Agencies (CSA's) visit www.gaylordventilation.com and go to "Find A Sales Rep/Agent".

SAFETY PRECAUTIONS

Tasks involved to replace UV Lamps involve potential exposure to high doses of UV light and live electrical components. There is a risk of serious injury to skin and eyes from UV light. There is a risk of shock, injury, and/or death from live electrical components.

Personal Protective Equipment

1. Eye protection that prevents 100% of UV light being transmitted through the lens must be worn at all times when replacing the UV Lamps on any ventilator that is energized and/or has the potential to be energized and expose personnel to UV light.
2. Whenever service work is performed it is recommended that long sleeve shirts and pants be worn to minimize the potential for inadvertent exposure of the skin to UV light.

Pressure Switches

There are two pressure switches used as the safety interlocks that monitor if all the XGS extractors are in place, and if the UV module access panels are closed and latched. If one or more XGS extractor(s) is missing and/or one or more UV module access panels are not in place the pressure switches will sense a pressure drop and shut down the UV system.

A 1/8" copper tube runs from a static pressure tap in the ventilator plenum into the ballast box. The copper tube is then connected to a clear vinyl tube which in turn is connected to the pressure switch. The vinyl tube is called a vacuum release tube and has a small hole midway in the tube to allow trapped pressure that may have been caused by the static tap plugging with grease, to bleed off. This safety feature will automatically shut off the UV System if the static tap becomes plugged. **Caution: If the vinyl tube needs replacing always use Gaylord Industries vacuum release tube. Refer to the Parts on Page 6-8.**

The pressure switches must be set prior to the initial operation of the ventilator, and after the exhaust volume has been verified in accordance with the Measuring Airflow section 6-1. To set the Pressure Switches proceed as follows (Refer to Figure 6-10-1).

CAUTION: Testing the pressure switches must be performed by Gaylord Certified Service Agent. For a list of Gaylord Certified Service Agencies (CSA's) visit www.gaylordventilation.com "Find A Sales Rep/Agent".

CAUTION: The pressure switches are located in the ballast box which is only assessable from the underside of the ventilator. Before you get started setting the pressure switches be sure to provide yourself secure means to the equipment in order to gain access to the critical components contained in the ELXC-SPC ballast box.

CAUTION: To set the pressure switches the exhaust fan must be on and therefore the ballast box will have live electrical components. Be extremely careful not to make contact with live electrical components. It is recommended that gloves be worn while adjusting the switches. There is a risk of shock, injury, and / or death from contact with live electrical components.

CAUTION (SHOCK HAZARD PRESENT): Verify that the SPADE CONNECTORS ARE IN PLACE PRIOR TO ANY ADJUSTING as illustrated in Figure 6-10-1. If not proceed to "Spade connector not in place procedure".

PRIOR to Starting (Site Conditions): The kitchen exhaust system is to be fully balanced. All doors and windows to be closed and sealed consistent with the ELXC-SPC future operation of the kitchen. Make up air and transfer air systems are to be activated and running during this procedure. Cooking equipment is to be OFF. Kitchen ambient temperatures are to be between 75°F and 85°F. Kitchens running outside these temperatures may not be set correctly. A follow up must be conducted with the kitchen after it is in operation to verify the operations of the UV system and its interlocks.

Setting the Pressure Switches (Cont.)

1. Confirm the ventilators are properly balanced and verify that if equipped the Demand Control System is running at 80 %.
2. Install all XGS extractors.
3. Remove the UV ballast box access cover located on the roof of the canopy for each ventilator section. A 7/16" nut driver will be needed. Gently push up the inner cover, then slide over and down to remove.
4. Use a short Philips screwdriver to remove the cover screws holding the plastic covers on both pressure switches, as shown in Figure 6-10-1.
5. Once the covers are removed, verify spade connectors are in place as shown in Figure 6-10-1.
CAUTION:*RISK OF SHOCK***** If the spade connectors shown are not in place turn off the power immediately. Follow the "Spade Connector not in Place Procedure" shown at the bottom of this page.
6. With gloves on and ventilator running turn the adjustment dial, as shown in Figure 6-10-1 on Pressure Switch "A", COUNTER CLOCKWISE until you hear a click. Then turn the adjustment dial pressure switch "B" COUNTER CLOCKWISE until you hear a "click". The Blue LED lights on the ballasts will illuminate, and the green UVi SYSTEM ON light, on the ventilator, will also come on. (NOTE: Both pressure switches need to be on for the UV system to turn on. LED lights will come on when the pressure switch closes).
7. Once the UV Lamps are activated, all Blue LED lights on the ballasts are illuminated, and the green UVi SYSTEM ON light on the ventilator is illuminated, gently turn pressure switch adjustment dial on pressure switch "A", CLOCKWISE until the UV Lamps deactivate, then back again slowly COUNTER CLOCKWISE until the UV system just comes back on. Repeat this process for pressure switch "B". The pressure switches are now set. (Note AirVantage systems should be set at 80% fan speed)
8. Replace the pressure switch covers.
9. Briefly secure the ballast box access cover. It must be in place to maintain proper pressurization in the ballast box enclosure.
10. **Test the System:** Remove the XGS extractor(s) at one end of the ventilator. The UVi SYSTEM ON light(s) must DEACTIVATE and the UV Lamps shut off in less than one second. If they do not, place the XGS extractors back in the ventilator and repeat steps 5 through 9.
11. Confirm the UVi SYSTEM ON lights reenergize once the extractors, doors, and UV access panels are closed.
12. Once the system is functioning properly, completely secure the ballast box access cover, and move on to the next ventilator section. Repeat as needed.

Spade Connector not in Place Procedure:

1. Shut off power to the UV Ventilator. Note: There are two breakers to deactivate.
 1. 208/240 UV module power.
 2. 120 VAC Power to the Command Center.
2. Verify power is shut down by checking voltage on terminal 6U on the Ventilation Control Board Panel. Also check terminals L3/L4. Voltage for both needs to be 0.
3. Place a Spade Terminal on the live Terminal shown in Figure 6-10-1, for both pressure switches as needed. Return to "Setting the Pressure Switches".

CAUTION: VERIFY SPADE CONNECTORS ARE IN PLACE PRIOR TO ADJUSTMENT. DO NOT ADJUST UNDER POWER UNLESS SPADE CONNECTOS ARE IN PLACE

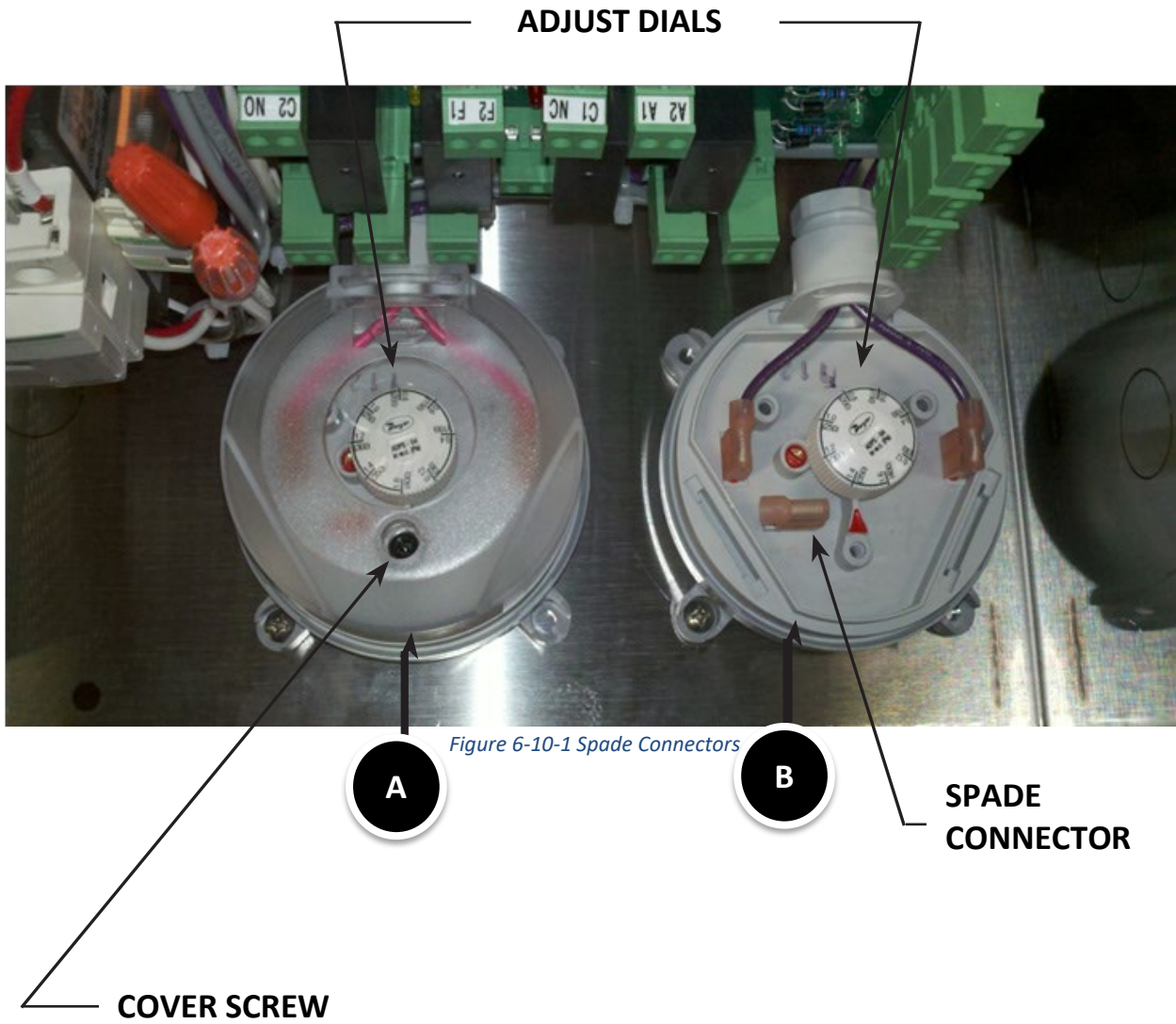

This Page Intentionally Left Blank

ITEM NO.	PART NUMBER	QTY	DESCRIPTION	MATERIAL
1	16045	4	1/4-20 HEX NUT, SS	301 SS
2	19732	4	4-40x3/4" MACHINE SCREW	301 SS
3	20135	4	ELX UV CHASE CAP	C-SS0-048
4	20139	4	1/4-20 x 3 1/4" HEX BOLT, SS	301 SS
5	20140	8	1/4" BONDED SEALING WASHER SS	301 SS
6	20263	1	ELX PANEL MOUNT RECEPTACLE 20-27	
7	20299	2	ELX UV CHASE GASKET	DSP1135M
8	22773	1	ELXC-SPC UV LEFT CHASE	C-SS0-048
9	22774	1	ELXC-SPC UV RIGHT CHASE	C-SS0-048
10	22776	1	5" SUV REAR FRAME	C-SS0-048
11	23769	6	SUV LIGHT SOCKET, 2 PIN	
12	23779	3	2.1 AMP SUV LAMP, 5"	
13	22781	1	ELXC-SPC SFT. UV WIRING CHASE	301 SS
14	22783	2	ELXC-SPC UV CHASE COVER	C-SS0-048
15	23380	6	SEALING GROMMET, .75-1.024IN DIA	SILICONE

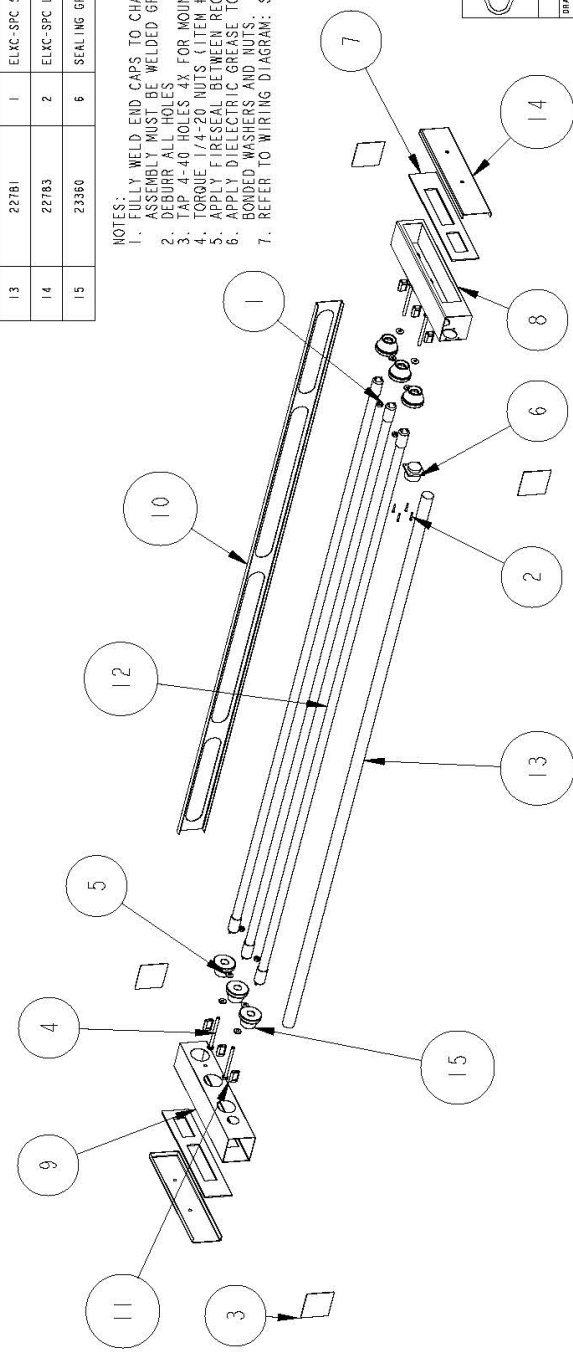
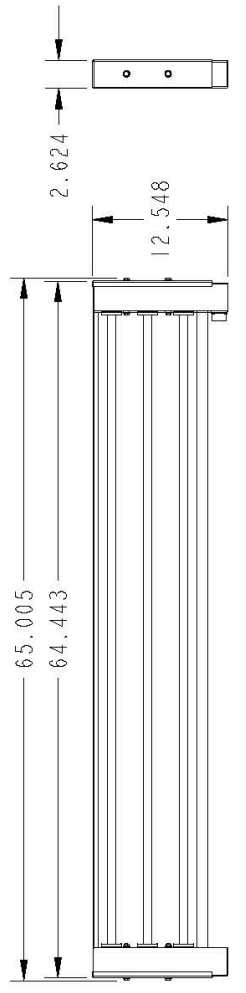

- NOTES:
- FULLY WELD END CAPS TO CHASE ENDS ALL AROUND, 4X. ASSEMBLY MUST BE WELDED GREASE AND WATER TIGHT UNLESS NOTED OTHERWISE.
 - DEBURR ALL HOLES.
 - TAP 4-40 HOLES 4X FOR MOUNTING OF RECEPTICAL (ITEM #7)
 - TORQUE 1/4-20 NUTS (ITEM #2) TO 7 IN-LBS
 - APPLY FIRESEAL BETWEEN RECEPTICAL AND CHASE (ITEMS #7, 9).
 - APPLY DIELECTRIC GREASE TO THREADS OF 1/4-20 BOLTS PRIOR TO ASSEMBLING BONDED WASHERS AND NUTS.
 - REFER TO WIRING DIAGRAM: SUV3-Ballasts Wiring_062416.dwg

GAYLORD INDUSTRIES
 Phone: 503.611.2010
 10801 S.W. 107th St.
 Portland, OR 97224
 E-Mail: gpi@10801sw107.com

Drawn By: H. RESPESS
 Date: 18-JUN-18
 Project Name: N/A
 Part Description: ELXC-SPC UV MODULE ASSY
 Drawing No: 76177

Sheet No: 1 of 1

REV.	ECN	DRAWN BY	DATE	REVISIONS	CHECKED BY
01	110319	RR	4/1/2020	Changed to Heraeus Lamps and Provided Bi-Pin Lamp connectors	RR

ITEM NO.	PART NUMBER	QTY	DESCRIPTION	MATERIAL
1	10756	30	1/4-20 X100N NUT CAP	SS
2	1436	120	1/8 IN RIVET 6/16 - 1/8 GRPP	SS
3	16017	23	1/4" SPILT WASHER	SS
4	2040	9	1/4" BONHEI SEALING WASHER	SS/RUBBER
5	22323	3	ESP ELECTRODE WELMENT ASSY	SS
6	22000	1	ELMC-SPC-30 ESP CELL JMWK END PANEL GASKET	SOLENOE EPDM/USHM
7	22805	12	ELMC-SPC-30 ESP CELL INSULATOR GASKET	SOLENOE EPDM/USHM
8	22600	26	ELMC-SPC-30 ESP CELL GROUND PLATE	AL .260
9	22601	24	ELMC-SPC-30 ESP CELL CHAMBE PLATE	AL .260
10	22812	13	ELMC-SPC-30 ESP CELL DOWNER LOWER	AL .048
11	22813	1	ELMC-SPC-30 ESP CELL FRONT BOTTOM	AL .260
12	22814	1	ELMC-SPC-30 ESP CELL FRONT TOP	AL .260
13	22815	1	ELMC-SPC-30 ESP CELL GROUND PLATE CTR	AL .260
14	22816	1	ELMC-SPC-30 ESP CELL JMWK END PANEL	AL .260
15	22817	1	ELMC-SPC-30 ESP CELL OUTER END PANEL	AL .260
16	22819	1	ELMC-SPC-30 ESP CELL INNER CELL MOUNT BOTTOM	AL .260
17	22820	1	ELMC-SPC-30 ESP CELL INLET BRACKET	AL .260
18	22821	1	ELMC-SPC-30 ESP CELL JMWK INLET BRACKET	AL .260
19	22824	32	ELMC-SPC-30 ESP CELL VOLT INSULATOR	POLYETHYLENE 2710
20	22825	2	ELMC-SPC-30 ESP CELL HANDLE	AL .260
21	22826	3	ELMC-SPC-30 ESP CELL GROUND LOCK TAB	AL .260
22	22906	1	ELMC-SPC-30 ESP CELL JMWK MOUNT BOTTOM	AL .260
23	23013	2	ELMC-SPC-30 ESP CELL DOWNER PAUL	AL .260
24	23014	9	ELMC-SPC-30 ESP CELL GROUND BOLT	AL 6660
25	23015	4	ELMC-SPC-30 ESP CELL CHAMBE INLET	AL 6660
26	23016	1	ELMC-SPC-30 ESP CELL TOP REAR BRACKET	AL .260
27	23017	1	ELMC-SPC-30 ESP CELL BOTTOM REAR BRACKET	AL .260
28	23018	1	ELMC-SPC-30 ESP CELL DOWNER CAP, TOP	AL .260
29	23019	1	ELMC-SPC-30 ESP CELL DOWNER CAP, BOTTOM	AL .260
30	76199	32	DOWNER WIRE ASSY, 300P 11A	TUNGSTEN

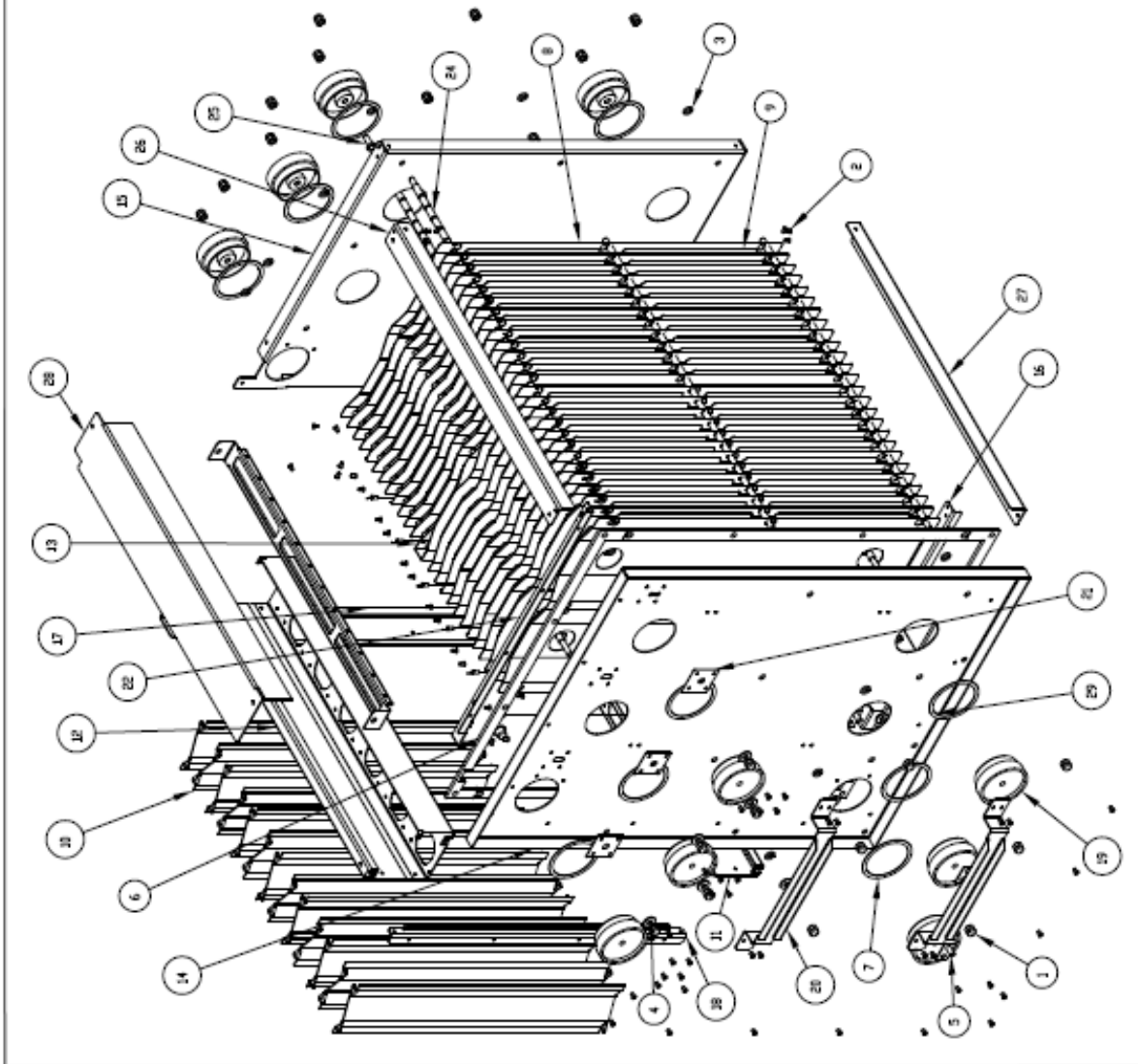

GAYLORD INDUSTRIES
 1000 E. 1st St.
 Grand Rapids, MI 49506
 Phone: 616-776-1000

GAYLORD

DATE: 11-16-17
 DRAWN BY: H. RESSESS
 CHECKED BY: N/A
 PROJECT NAME: N/A

UNIT OF MEASURE: N/A
 SCALE: N/A
 SHEET NO.: 00
 TOTAL SHEETS: 01 OF 02

PART DESCRIPTION: ELMC-SPC 2000 CFM ESP CELL ASSEMBLY
 DRAWING NO.: 76165

ITEM NO.	PART NUMBER	QTY	DESCRIPTION	MATERIAL
1	0813	4	40-24 HEX LOCK NUT	SS
2	55359	4	40-24 x 3/8 STUD	SS
3	56478	10	48-28 x 1/4 SCREW	SS
4	22796	1	ELC-SPC OPACITY SENSOR WINDOW	JIS GLASS, TEMPERED
5	22857	1	ELC-SPC OPACITY SENSOR ENCL BODY	.J48P SS
6	22858	1	ELC-SPC OPACITY SENSOR ENCL BACK	.J48P SS
7	22859	1	ELC-SPC OPACITY SENSOR ENCL END PANEL	.J48P SS
8	22860	1	ELC OPACITY SENSOR ENCL MOUNTING PANEL	.J48P SS
9	22862	1	ELC-SPC OPACITY SENSOR MOUNTING BRACKET	.J48P SS
10	22862	1	ELC-SPC OPACITY SENSOR ENCLOSURE COVER	.J48P SS
11	22887	1	OPACITY SENSOR COLLECTOR	N/A

NOTES

1. WELD ITEMS #5-8 TOGETHER ALONG ENTIRE PERIMETER EDGES
2. TAP ENCLOSURE BODY ITEM #5 FOR #8-32 SCREWS
3. USE DOUBLE-SIDED TAPE TO ATTACH GLASS WINDOW (ITEM #4) TO COVER PLATE (ITEM #10)
4. ASSEMBLY MUST BE WELDED GREASE AND WATER TIGHT UNLESS NOTED OTHERWISE

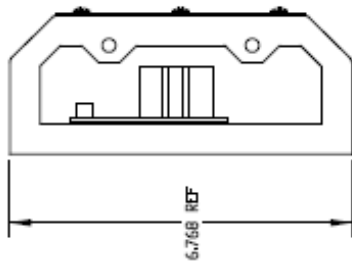
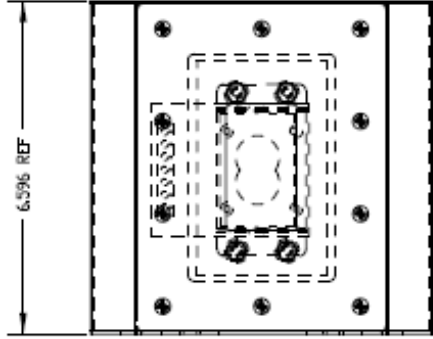
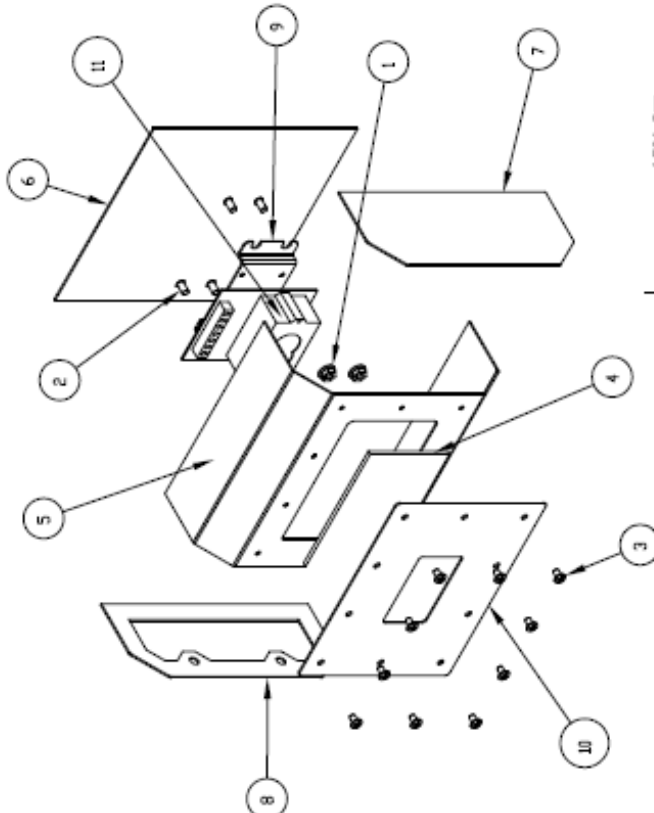



GAYLORD INDUSTRIES
 1000 S.W. 4th Ave
 Fort Lauderdale, FL 33304
 Phone: 954-575-1100
 Fax: 954-575-1101
 E-Mail: sales@gaylord.com

Drawn By: H. RESPASS
 CHECKED BY: [Signature]
 PROJECT NAME: N/A; SEE TABLE

DATE: 11-14-Apr-2017

REVISIONS:

DATE	BY	DESCRIPTION
11-14-Apr-2017	H. RESPASS	Initial Release

76360

1 of 1

ITEM NO.	PART NUMBER	QTY	DESCRIPTION	MATERIAL
1	22009		BALL VALVE ACTUATOR, 2"	N/A
2	22960		BALL VALVE ACTUATOR, 2"	N/A
3	22961		BALL VALVE ACTUATOR, 2"	N/A
4	38347		BALL VALVE ACTUATOR, 2"	N/A
5	22961		BALL VALVE ACTUATOR, 2"	N/A
6	44508		BALL VALVE ACTUATOR, 2"	N/A
7	2_IN_SCH_40_SS		BALL VALVE ACTUATOR, 2"	N/A
8	44508		BALL VALVE ACTUATOR, 2"	N/A
9	22961		BALL VALVE ACTUATOR, 2"	N/A

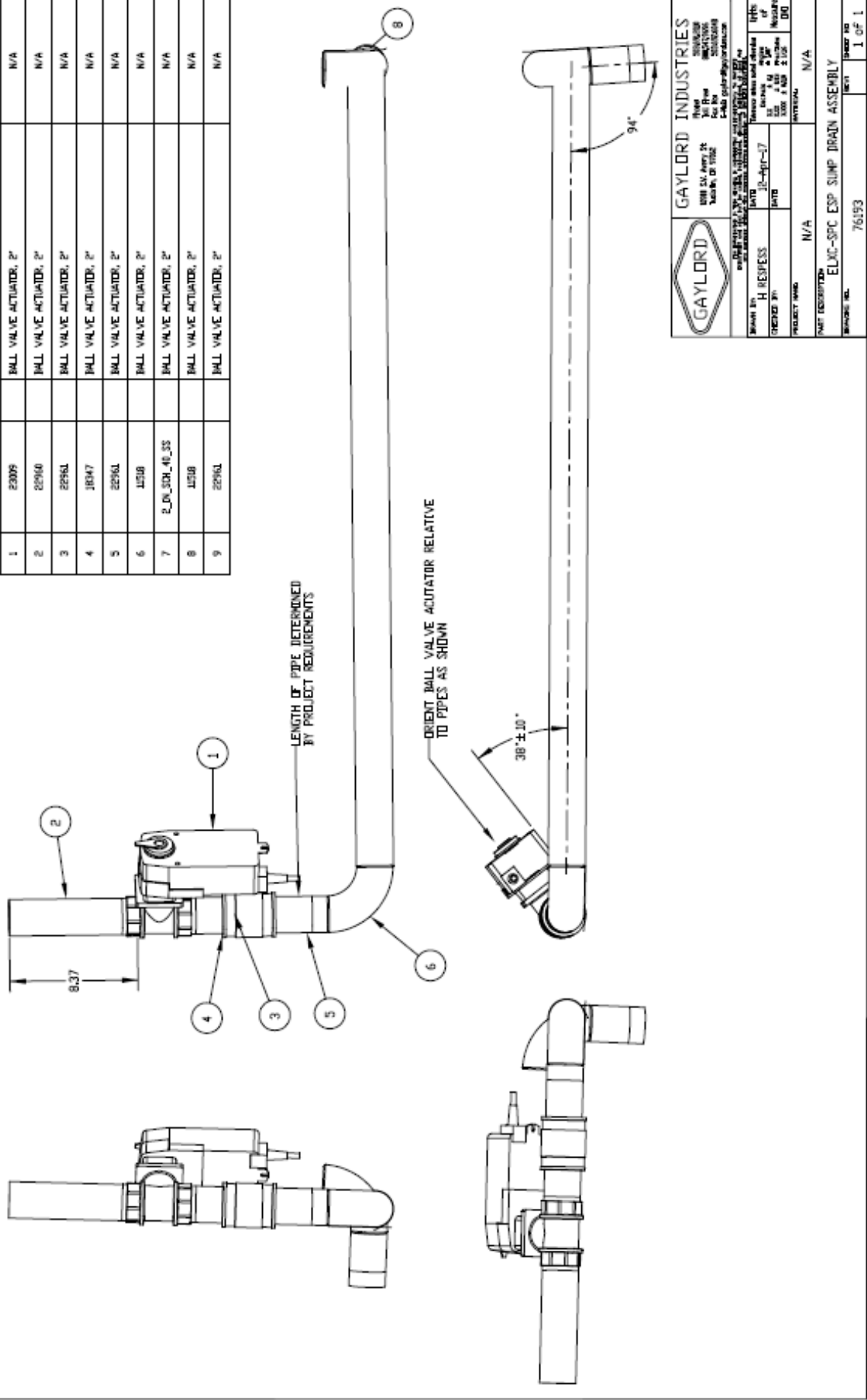

GAYLORD INDUSTRIES

2200 S. AVENUE 25
MIDLAND, TEXAS 79701
Tel: 806-835-0000
Fax: 806-835-0000
E-mail: gaylor@gaylord.com

GAYLORD

DESIGNED BY: H. RESSESS
DATE: 10-Apr-17
CHECKED BY: JWB
DATE: 10-Apr-17
PROJECT NAME: N/A
MATERIAL: N/A

DATE DESCRIBED: ELXC-SFC ESP SUMP DRAIN ASSEMBLY
DRAWING NO.: 76193
SHEET NO.: 1 OF 1

Parts - Wash Control Cabinet – Detergent Pump

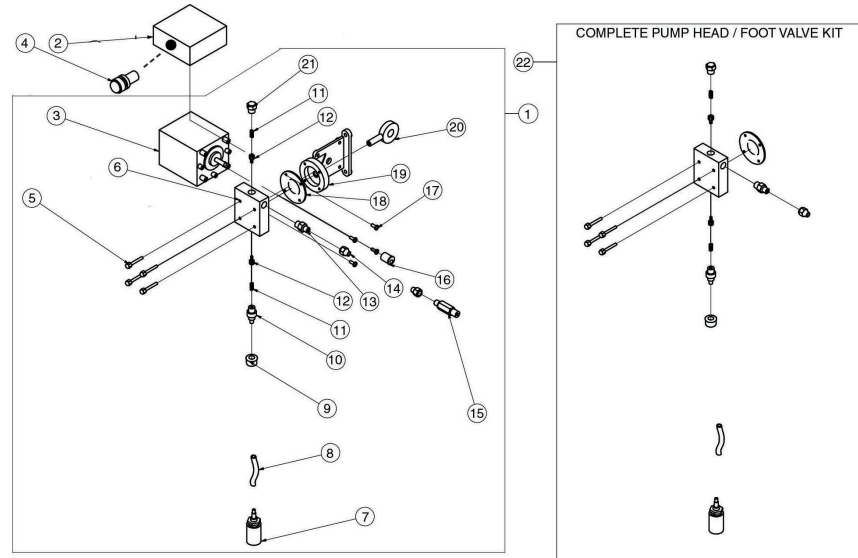
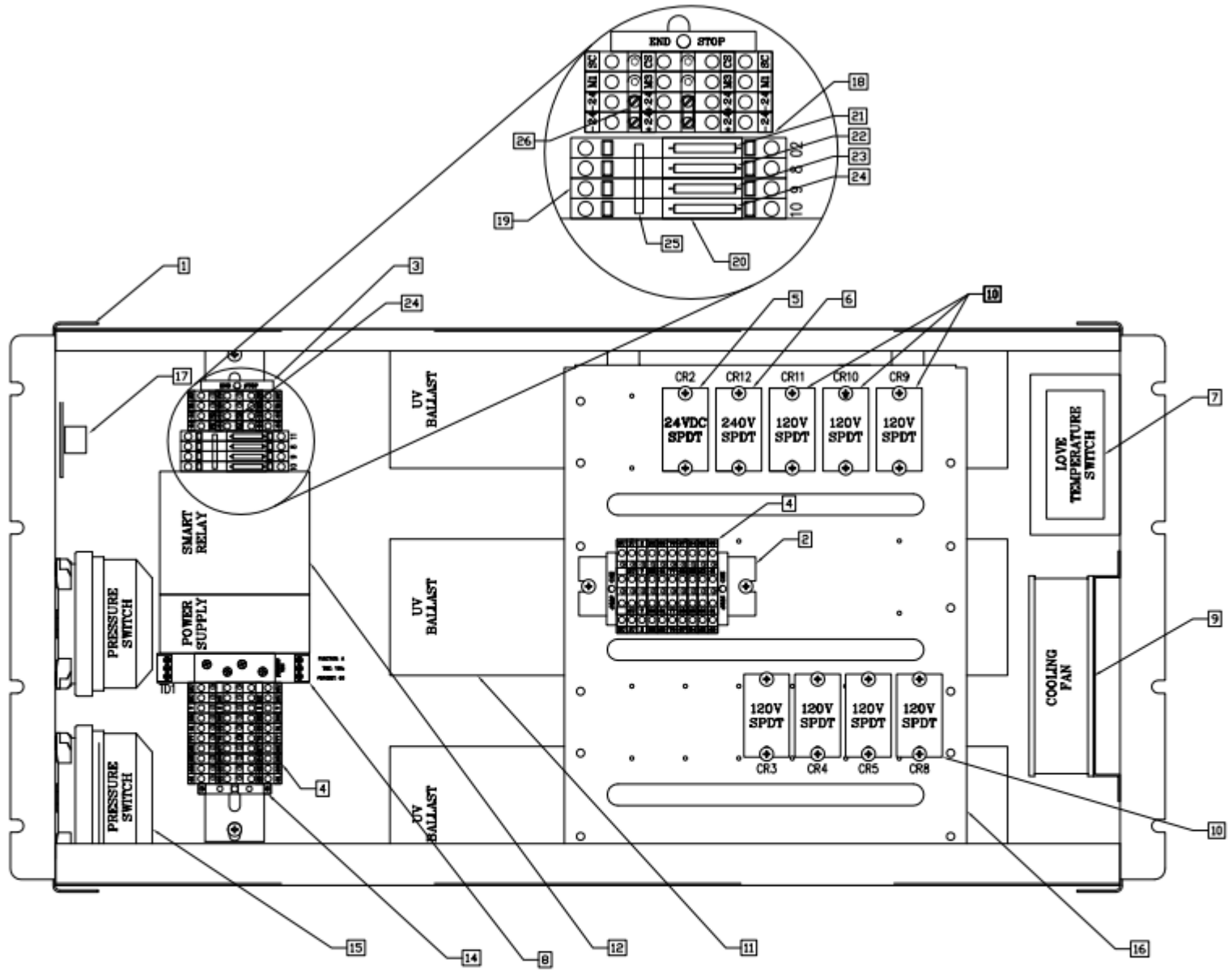

Figure 7-5-1 GPC-7000 SPC Detergent/Chemical Pump Location

Table T-7-5-1 Detergent Pump Part Numbers

Detergent Pump Parts List			
Pc #	DECRPTION	QTY	GAYLORD PART NO.
1	Detergent Pump - Complete	1	10222
2	Electrical J-Box (not sold separately)	1	n/a
3	Pump Motor (not sold separately)	1	n/a
4	Detergent Pump Test Switch	1	10238
5	Pump Head Screws (sold with Kit Part No. 10275)	4	n/a
6	Pump Head, Sold as a Kit. See Part No 10275	1	n/a
7	Foot Valve	1	10269
8	Vinyl Tubing 22" Long	1	10272
9	Tube Nut (not sold with Kit Part No. 10275)	1	n/a
10	Bottom Adaptor with "O" Ring (sold with Kit Part No. 10275)	1	n/a
11	Spring (sold with Kit Part No. 10275)	1	n/a
12	Poppet Check (sold with Kit Part No. 10257)	2	n/a
13	Brass Outlet (sold with Kit Part No. 10275)	1	n/a
14	Tube Nut - Brass (sold with Kit Part No. 10275)	1	n/a
15	Check Valve - Brass	1	10265
16	Adjustable Cam Assembly	1	20466
17	Bracket Motor Mounting Screws (not sold separately)	4	n/a
18	Diaphragm (sold with Kit Part No. 10275)	1	n/a
19	Pump Bracket (not sold separately)	1	n/a
20	Yoke and Bearing Assembly	1	n/a
21	Top Cap (sold with Kit Part No. 10275)	1	n/a
22	Complete Pump Head / Foot Valve Kit	1	10275

Ballast Box Enclosure – See Chapter 8, Page 8-4 for Internal Wiring



26	20624	INTERNAL JUMPER DIN (2 of 10) 10-POLE	2				
25	23239	PHX 10 POLE JUMPER (4 of 10)	1				
24	23156	R1 - 8.5 KOHM RESISTOR	1				
23	23157	R2 - 4.4 KOHM RESISTOR	1				
22	23158	R3 - 3.0 KOHM RESISTOR	1	11	22894	ALLANSON UVB164T6-2100-MV-PD-P BALLAST	3
21	23155	R4 - 2.2 KOHM RESISTOR	1	10	23049	AZ2280-1C-120AF 120V SPDT	7
20	23159	PHX - RESISTOR HOLDER	4	9	19430	DAYTON 4WT47A FAN	1
19	22738	FUSE BLOCK CONTACT	4	8	22789	SIEMENS 7PV1508-1AW30 DELAY ON MAKE TDR	1
18	23199	RESISTOR TERMINAL END BLOCK PLATE	1	7	76087	LOVE SERIES TCS THERMOCOUPLE SWITCH (KIT)	1
17	22998	ALLANSON CURRENT SINKING CIRCUIT BOARD	1	6	22287	AZ2280-1C-240AF 240V SPDT	1
16	22807	PUV RELAY BACK BOARD (SS)	1	5	22786	AZ2280-1C-24DF 24VDC SPDT	1
15	20489	DWYER PRESSURE SWITCH	2	4	20626	TERMINAL BLOCK DIN DOUBLE GRAY	22
14	20629	GROUND BLOCK DIN SGL GRN/YEL	1	3	16235	TERMINAL BLOCK END STOP	3
13	20824	PHOENIX STEP-PS/ 1AC/240C/0.75	1	2	11384	DIN RAIL	2
12	22864	EATON EASY 512-DC-RC SMART RELAY	1	1	76243	PCV BALLAST ENCLOSURE ASSEMBLY (WELDMENT 22887)	1
ITEM NO.	GPN	DESCRIPTION	QTY.	ITEM NO.	GPN	DESCRIPTION	QTY.

This Page Intentionally Left Blank

Wiring Diagram – Power Pack Enclosure / ESP Section

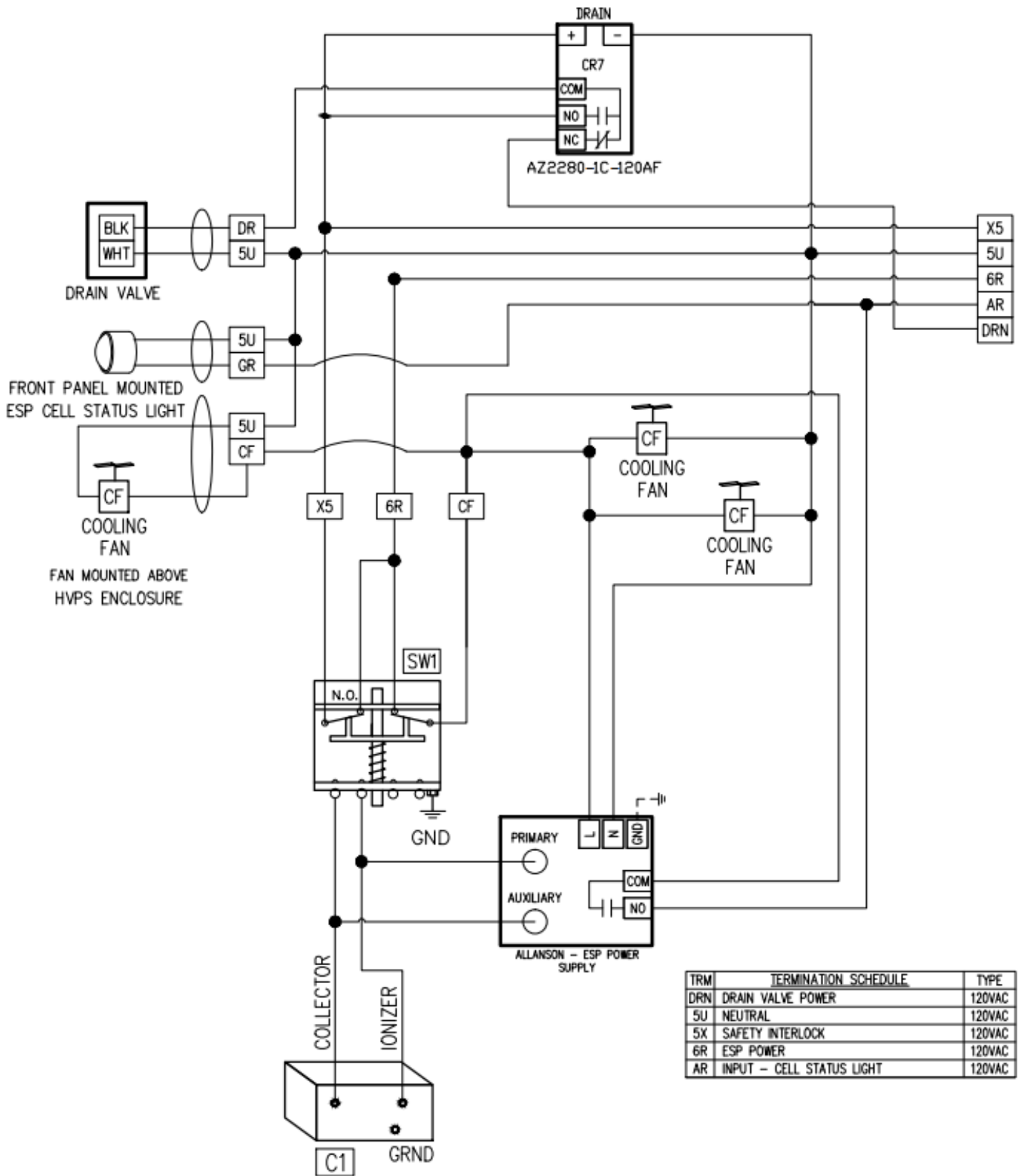

Wiring Diagram – Ballast Box / Hood Sub-Assembly Connections

AVHC TO OPACITY COLLECTOR AND EMITTER ENCLOSURES (24VDC)

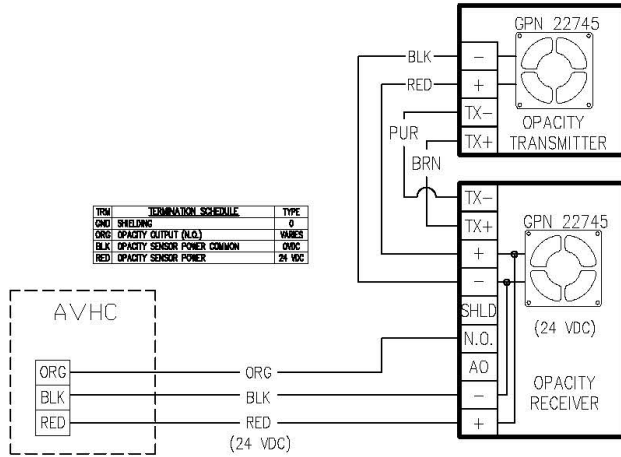

DCA TO OPACITY COLLECTOR AND EMITTER ENCLOSURES (12VDC)

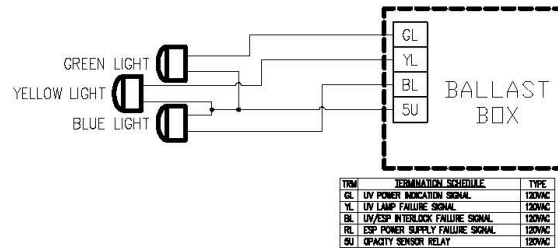
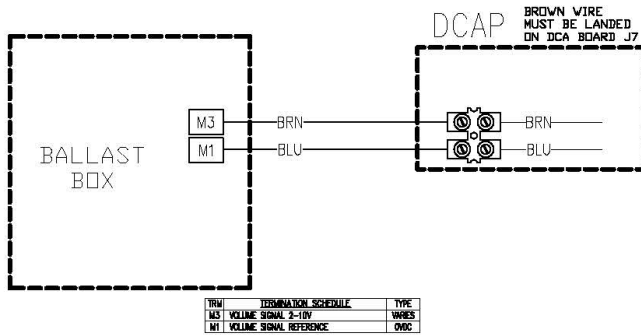
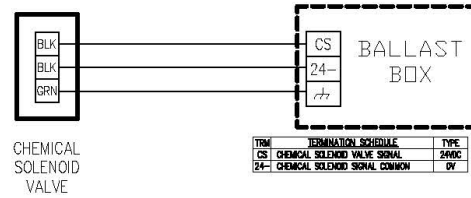
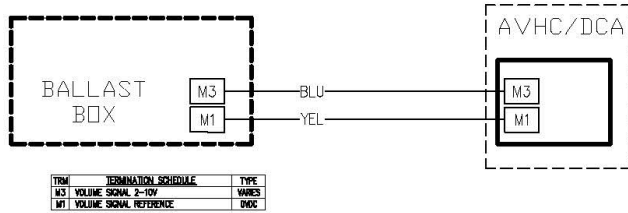
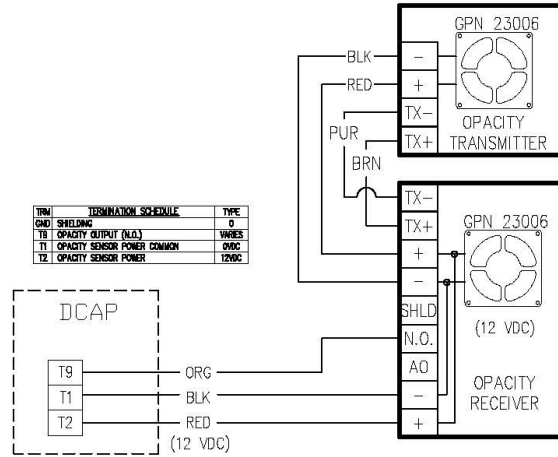

Wiring Diagram – AVHC Control

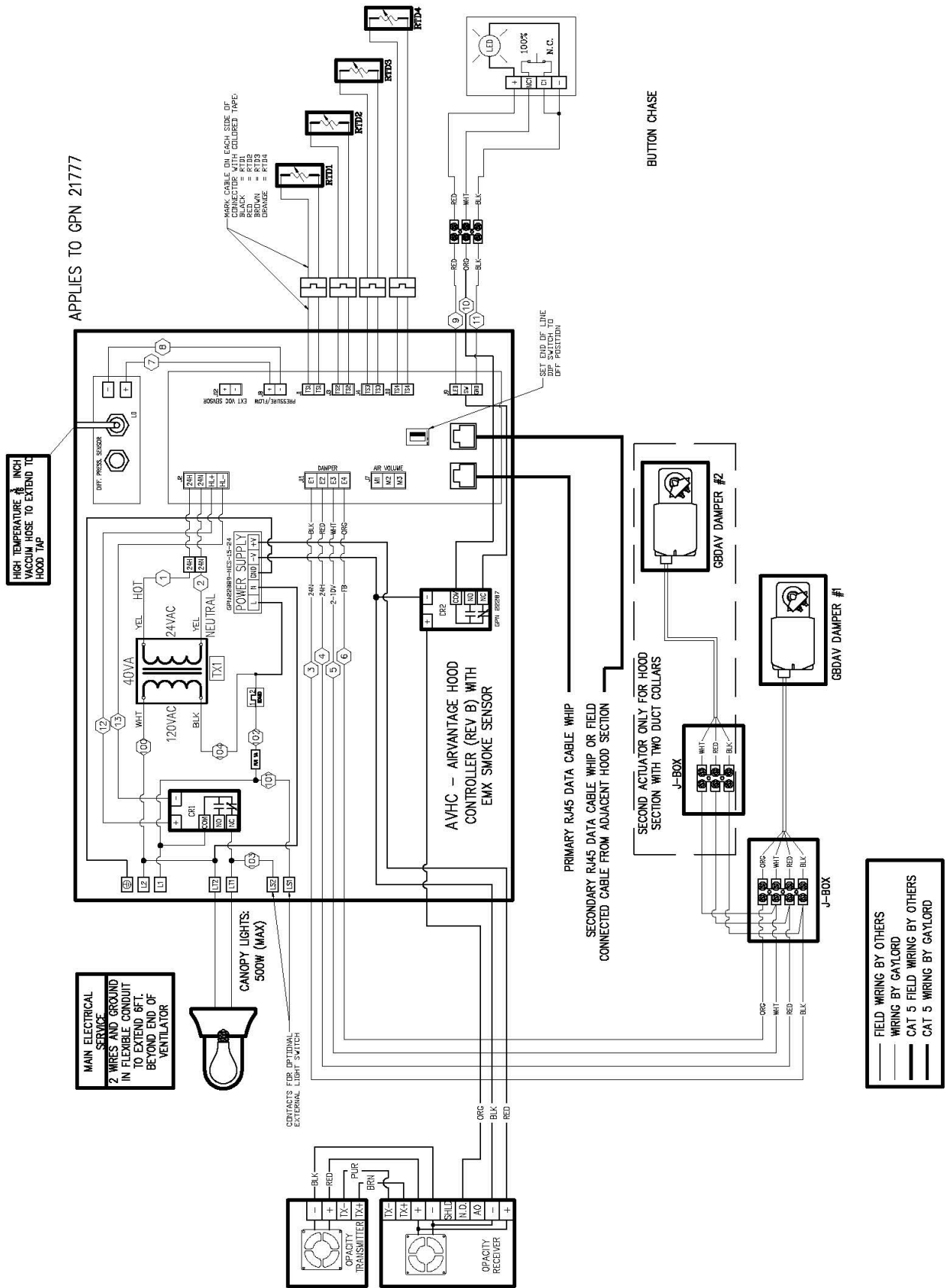

MAIN ELECTRICAL SERVICE
2 WIRES AND GROUND
IN FLEXIBLE CONDUIT
TO EXTEND SET
BEYOND END OF
VENTILATOR

FIELD WIRING BY OTHERS
WIRING BY GAYLORD
CAT 5 FIELD WIRING BY OTHERS
CAT 5 WIRING BY GAYLORD

Wiring Diagram – Ballast Box Enclosure

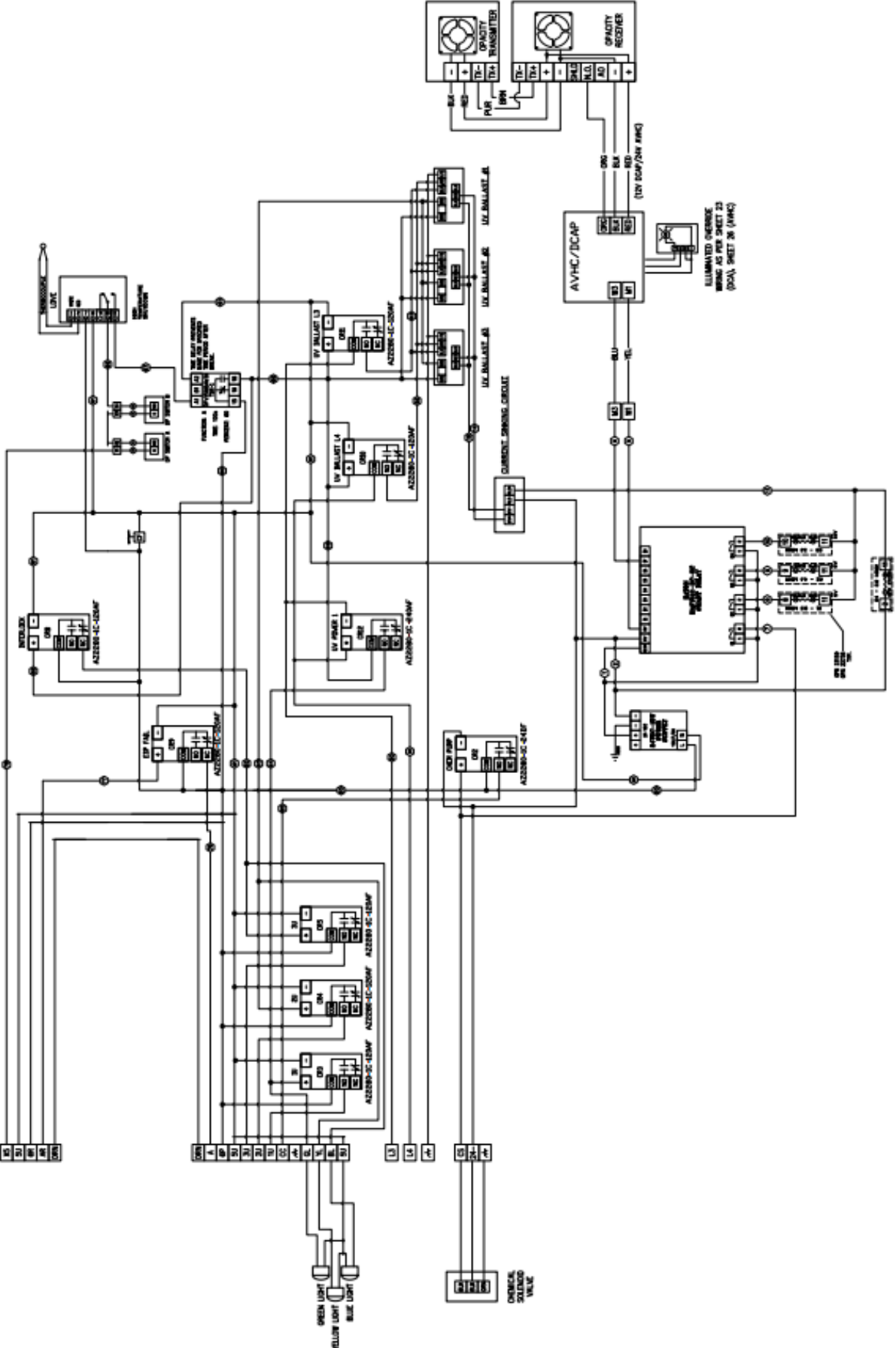

Wiring Diagram – C-7000 SPC Supplemental

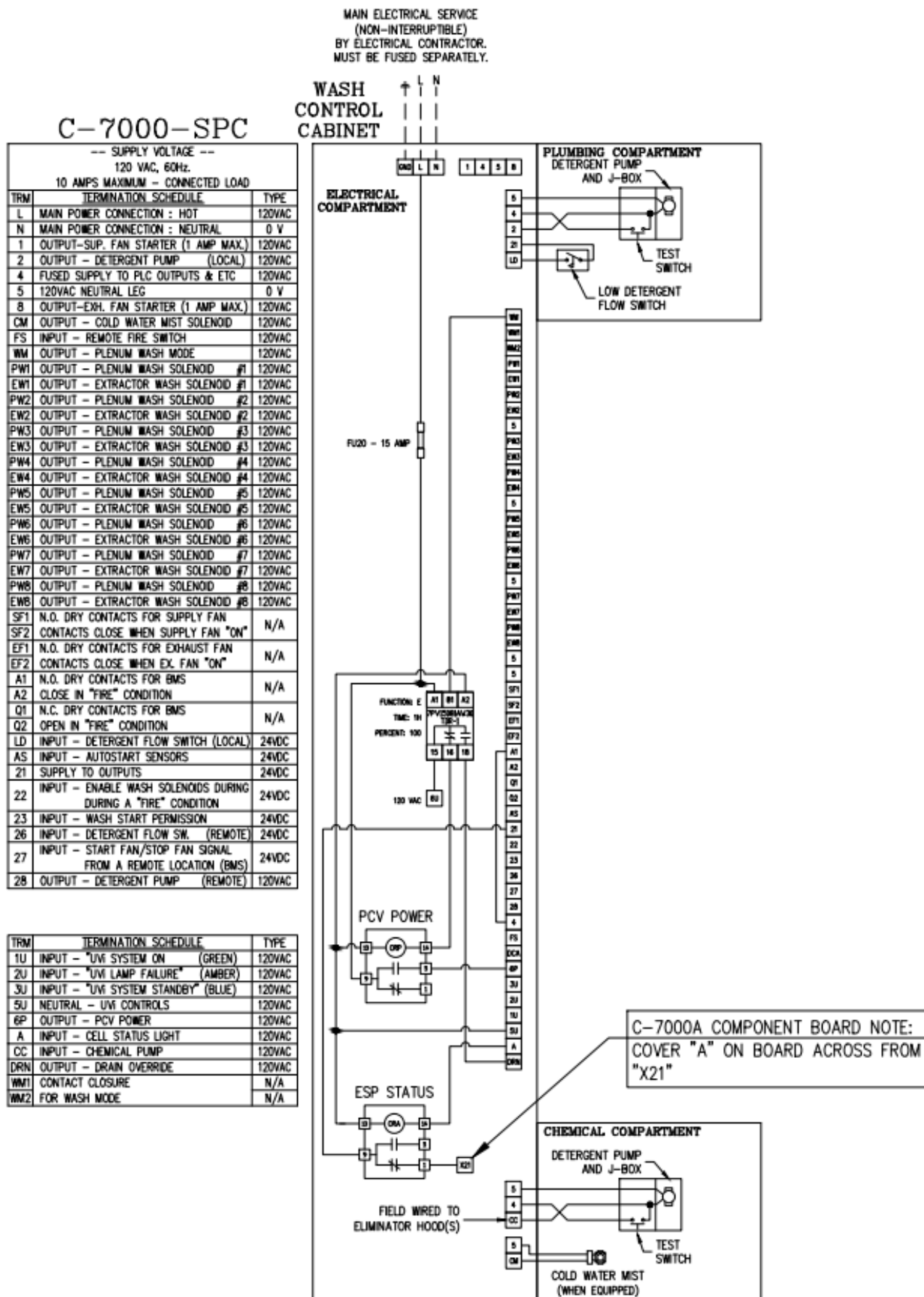

Wiring Diagram – Multiple GPC 7000 SPC Wiring to Single AV Command Center

– Primary/Secondary

MAIN ELECTRICAL SERVICE
(NON-INTERRUPTIBLE)
BY ELECTRICAL CONTRACTOR.
MUST BE FUSED SEPARATELY.

C-7000-SPC

TRM	TERMINATION SCHEDULE	TYPE
L	MAIN POWER CONNECTION : HOT	120VAC
N	MAIN POWER CONNECTION : NEUTRAL	0 V
1	OUTPUT-SUP. FAN STARTER (1 AMP MAX.)	120VAC
2	OUTPUT - DETERGENT PUMP (LOCAL)	120VAC
4	FUSED SUPPLY TO PLC OUTPUTS & ETC	120VAC
5	120VAC NEUTRAL LEG	0 V
8	OUTPUT-EXH. FAN STARTER (1 AMP MAX.)	120VAC
CM	OUTPUT - COLD WATER MIST SOLENOID	120VAC
FS	INPUT - REMOTE FIRE SWITCH	120VAC
WM	OUTPUT - PLENUM WASH MODE	120VAC
PW1	OUTPUT - PLENUM WASH SOLENOID #1	120VAC
EW1	OUTPUT - EXTRACTOR WASH SOLENOID #1	120VAC
PW2	OUTPUT - PLENUM WASH SOLENOID #2	120VAC
EW2	OUTPUT - EXTRACTOR WASH SOLENOID #2	120VAC
PW3	OUTPUT - PLENUM WASH SOLENOID #3	120VAC
EW3	OUTPUT - EXTRACTOR WASH SOLENOID #3	120VAC
PW4	OUTPUT - PLENUM WASH SOLENOID #4	120VAC
EW4	OUTPUT - EXTRACTOR WASH SOLENOID #4	120VAC
PW5	OUTPUT - PLENUM WASH SOLENOID #5	120VAC
EW5	OUTPUT - EXTRACTOR WASH SOLENOID #5	120VAC
PW6	OUTPUT - PLENUM WASH SOLENOID #6	120VAC
EW6	OUTPUT - EXTRACTOR WASH SOLENOID #6	120VAC
PW7	OUTPUT - PLENUM WASH SOLENOID #7	120VAC
EW7	OUTPUT - EXTRACTOR WASH SOLENOID #7	120VAC
PW8	OUTPUT - PLENUM WASH SOLENOID #8	120VAC
EW8	OUTPUT - EXTRACTOR WASH SOLENOID #8	120VAC
SF1	N.O. DRY CONTACTS FOR SUPPLY FAN	N/A
SF2	CONTACTS CLOSE WHEN SUPPLY FAN "ON"	N/A
EF1	N.O. DRY CONTACTS FOR EXHAUST FAN	N/A
EF2	CONTACTS CLOSE WHEN EX. FAN "ON"	N/A
A1	N.O. DRY CONTACTS FOR BMS	N/A
A2	CLOSE IN "FIRE" CONDITION	N/A
Q1	N.C. DRY CONTACTS FOR BMS	N/A
Q2	OPEN IN "FIRE" CONDITION	N/A
LD	INPUT - DETERGENT FLOW SWITCH (LOCAL)	24VDC
AS	INPUT - AUTOSTART SENSORS	24VDC
21	SUPPLY TO OUTPUTS	24VDC
22	INPUT - ENABLE WASH SOLENOIDS DURING DURING A "FIRE" CONDITION	24VDC
23	INPUT - WASH START PERMISSION	24VDC
26	INPUT - DETERGENT FLOW SW. (REMOTE)	24VDC
27	INPUT - START FAN/STOP FAN SIGNAL FROM A REMOTE LOCATION (BMS)	24VDC
28	OUTPUT - DETERGENT PUMP (REMOTE)	120VAC

TRM	TERMINATION SCHEDULE	TYPE
1U	INPUT - "UVI SYSTEM ON" (GREEN)	120VAC
2U	INPUT - "UVI LAMP FAILURE" (AMBER)	120VAC
3U	INPUT - "UVI SYSTEM STANDBY" (BLUE)	120VAC
5U	NEUTRAL - UVI CONTROLS	120VAC
6P	OUTPUT - PCV POWER	120VAC
A	INPUT - CELL STATUS LIGHT	120VAC
CC	INPUT - CHEMICAL PUMP	120VAC
DRN	OUTPUT - DRAIN OVERRIDE	120VAC
WM1	CONTACT CLOSURE FOR WASH MODE	N/A
WM2	CONTACT CLOSURE FOR WASH MODE	N/A

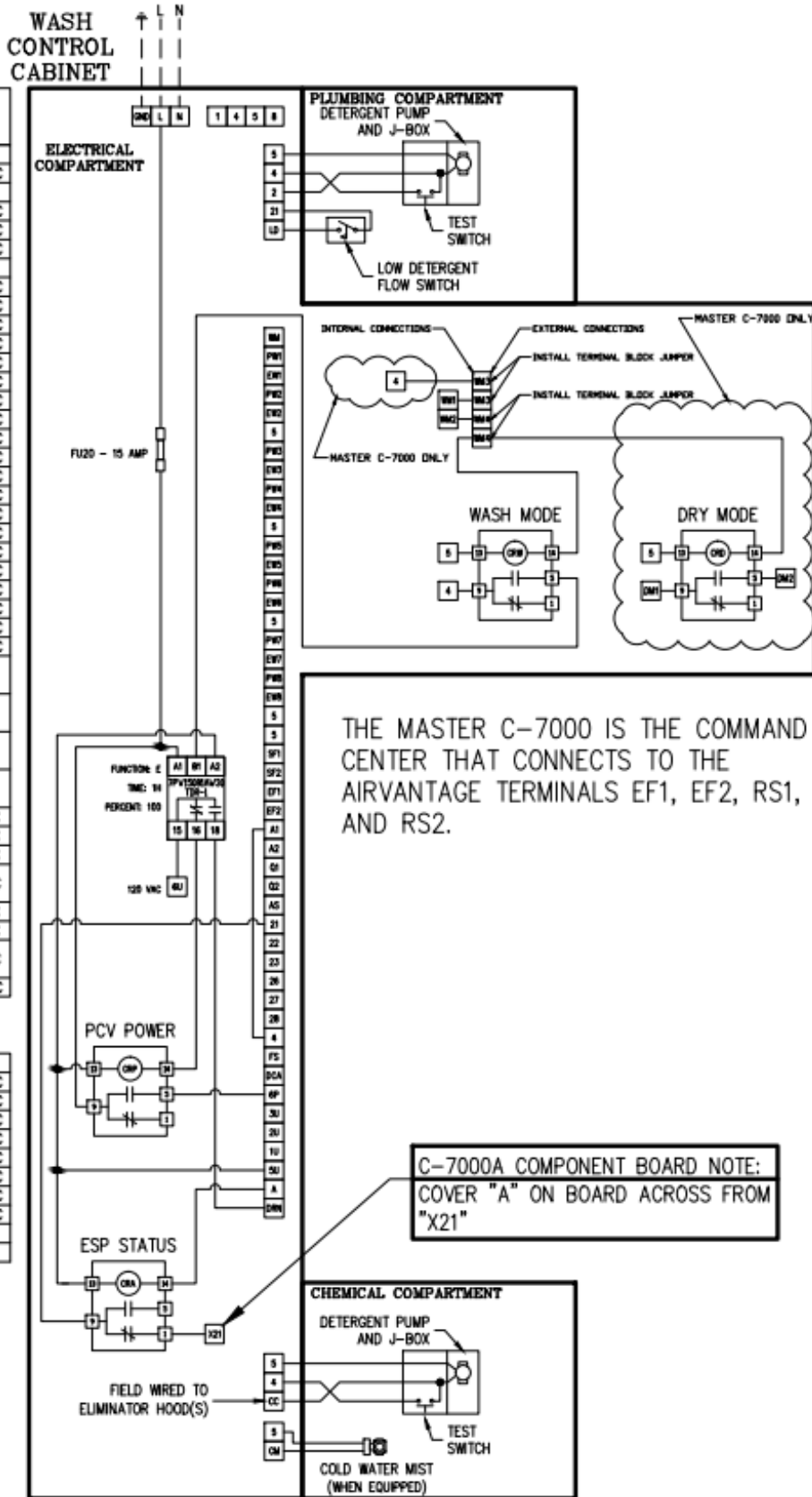

THE MASTER C-7000 IS THE COMMAND CENTER THAT CONNECTS TO THE AIRVANTAGE TERMINALS EF1, EF2, RS1, AND RS2.

C-7000A COMPONENT BOARD NOTE: COVER "A" ON BOARD ACROSS FROM "X21"

Wiring Diagram – UV Module

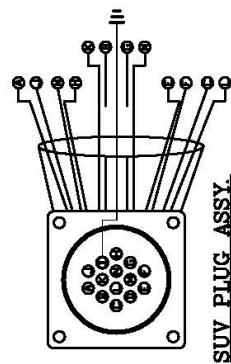
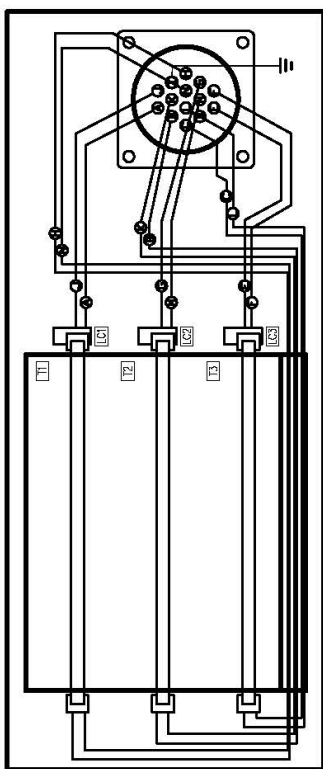
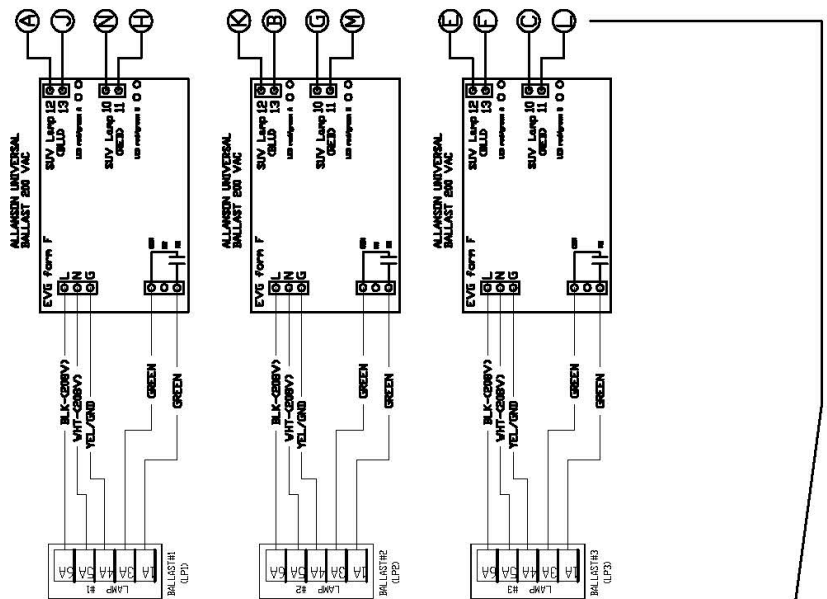

Wiring Diagram – Wiring Diagram – DCA Control

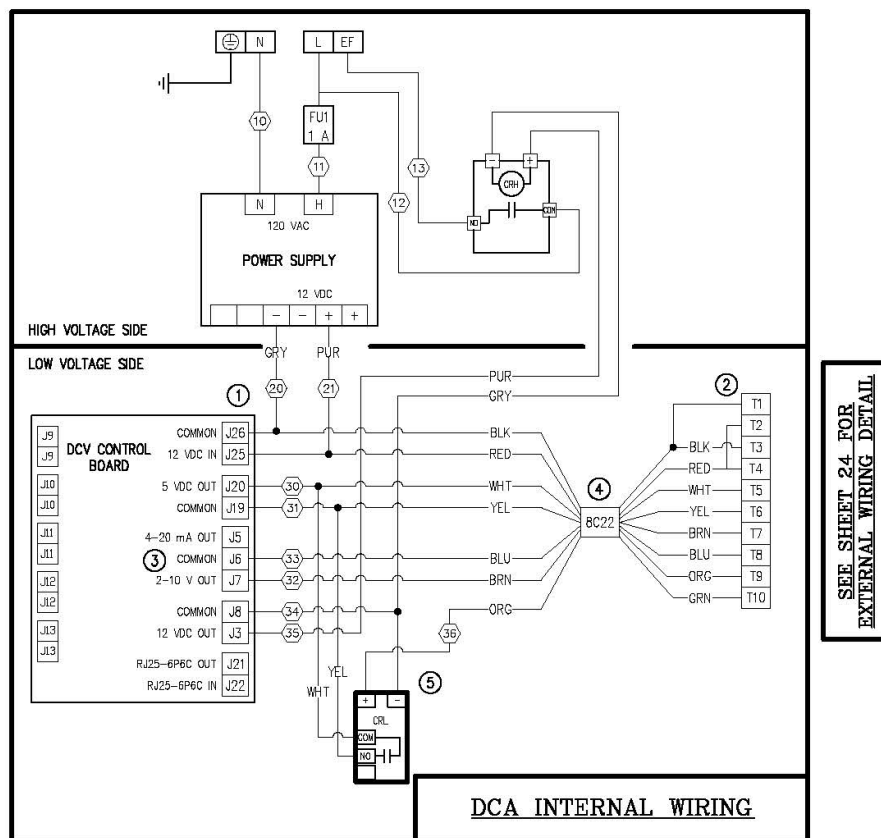
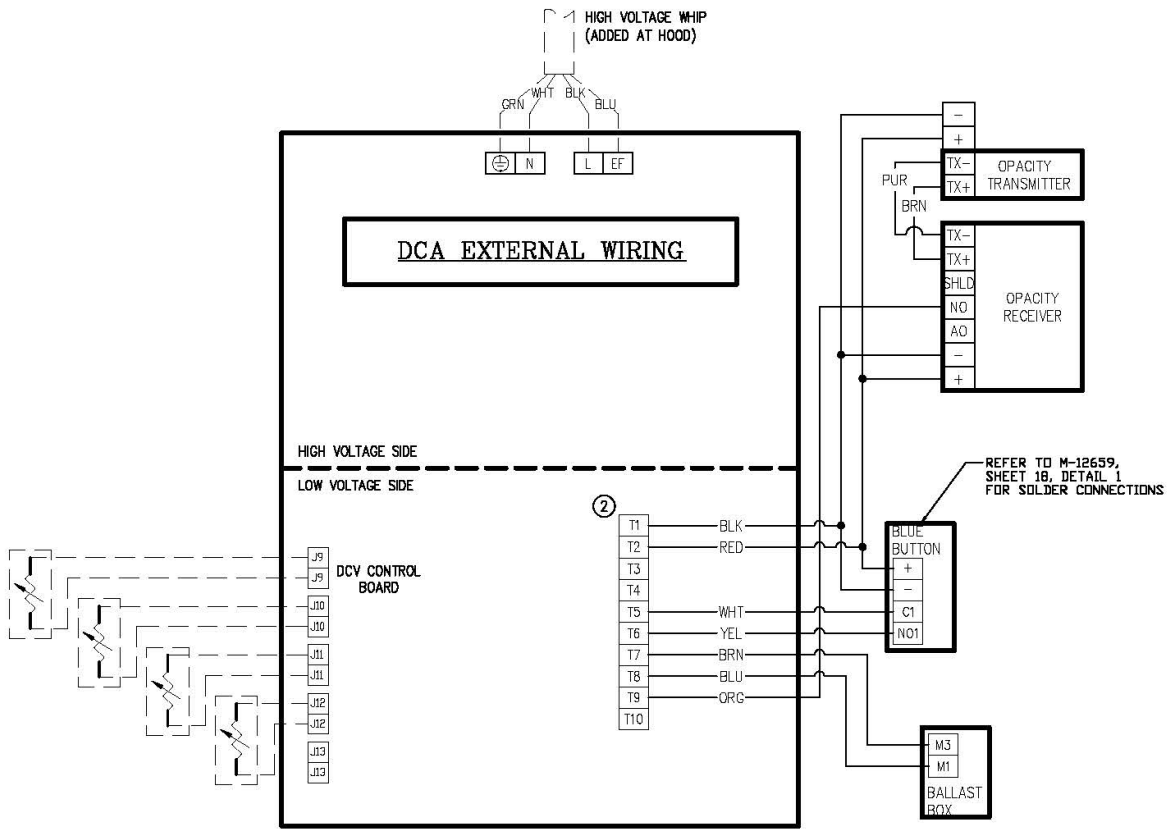

Installation – Cont.

Code Compliance

Ventilators must be installed to comply with all applicable codes.

1. Ventilator to be installed in accordance with NFPA-96, Standard for Ventilation Control and Fire Protection of Commercial Cooking Operations, the IMC, International Mechanical Code, and all other local applicable codes.
2. All plumbing and electrical must comply with the applicable codes.
3. Contractors must review applicable codes with code authorities before approving drawings for fabrication.
4. Special attention must be given to code regulations relative to clearances from surrounding combustible constructions (walls, ceilings, etc.).

Permits

IMPORTANT NOTE: Most building departments require the ventilator (hood) permit separate from any other general building permit. In addition, if a Fire Extinguishing System is involved a separate permit from the ventilator permit is typically required. The ventilator permit is typically obtained through the plan review department and the Fire Extinguishing System permit through the fire prevention bureau. The installing contractor must check with local building departments for their requirements, and to obtain necessary permits.

Ventilator Listing

The Gaylord Model ELXC-SPC Series ventilators are listed to UL 710, UL 710C respectively, and recognized by ETL. Any modification made to the ventilator at the jobsite will void the listing.

Hanging the Ventilator

Use the following guidelines for hanging the Gaylord ventilator:

1. The maximum section length of a Gaylord Eliminator is 14'-0". Ventilators longer than 14'-0" are made up of multiple sections.
2. The weight of the ventilator is shown on the Gaylord Submittal Drawings. (Note ELXC-SPC hoods weight approximately 150 lb. per linear foot of hood.) **Hood wet weight shall require an additional 1000 lbs. per exhaust duct. Installer to confirm provisions are in place to support the additional load.**
3. Each ventilator section has a full-length rear mounting bracket for bolting to the wall and/or hanging from the overhead. There are two other full-length hanging brackets; the Middle Mounting Bracket and the Front Mounting Bracket for hanging from the overhead (refer to Figure A-2-1). All three Hanging Brackets have pre-punched hole centers for hanging from the overhead. Hanging rods to be supplied by the ventilator installer. If the rear bracket is used for bolting to the wall the holes must be pre-drilled by the installing contractor at a support point in the wall. Refer to Table T-A-2-1 for minimum number of mounting points.
4. It is recommended that the number of hanging rods used be no less than the recommend minimum as shown on Table T-A-2-1.
5. The ventilator(s) must be installed at the distance from the finish floor and the minimum side overhang dimension from the end of the ventilator to the cooking equipment as shown on the Gaylord Submittal Drawings.
6. When there is a continuous ventilator made up of two or more sections it is recommended that each *ventilator section is hung individually. Angles are provided at the top of the sections for bolting together.* The bolts are provided by Gaylord Industries. Hem strips and bolts are provided by Gaylord Industries for joining the ventilators on the underside where visible.

7. CAUTION: Do not cover or restrict ventilation openings at the UV Ballast Box, front panel, drain side airspace or other ventilation opening with building insulation. Note: The Eliminator Series Ventilator is listed for limited clearance to combustibles under UL 710 with the ventilation openings exposed. Failure to comply with this requirement shall void the warranty.

Table 1 A-2-1

Recommend Minimum Mounting Devices					
Rear Mounting Bracket, Bolting to Wall or Hanging With Rods		Middle Mounting Bracket Hanging Rods		Front Mounting Bracket Hanging Rods	
Max. Distance From End of Ventilator Section	Max. Spacing Between Supports	Max. Distance From End of Ventilator Section	Max. Spacing Between Supports	Max. Distance From End of Ventilator Section	Max. Spacing Between Supports
12"	42"	24"	48"	12"	42"

REAR/ MIDDLE/ FRONT MOUNTING BRACKETS

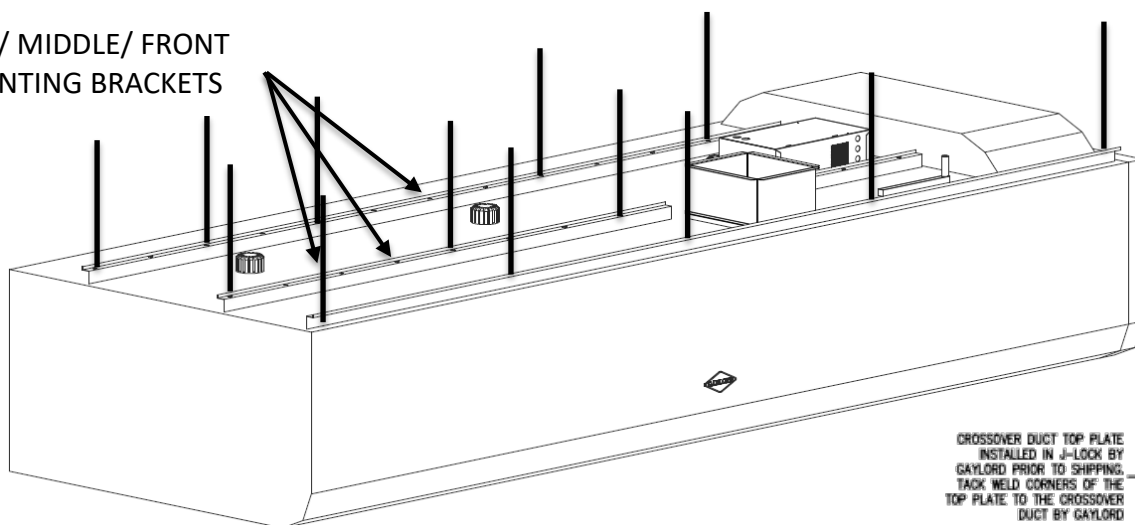

Figure A-2-2 Mounting Brackets

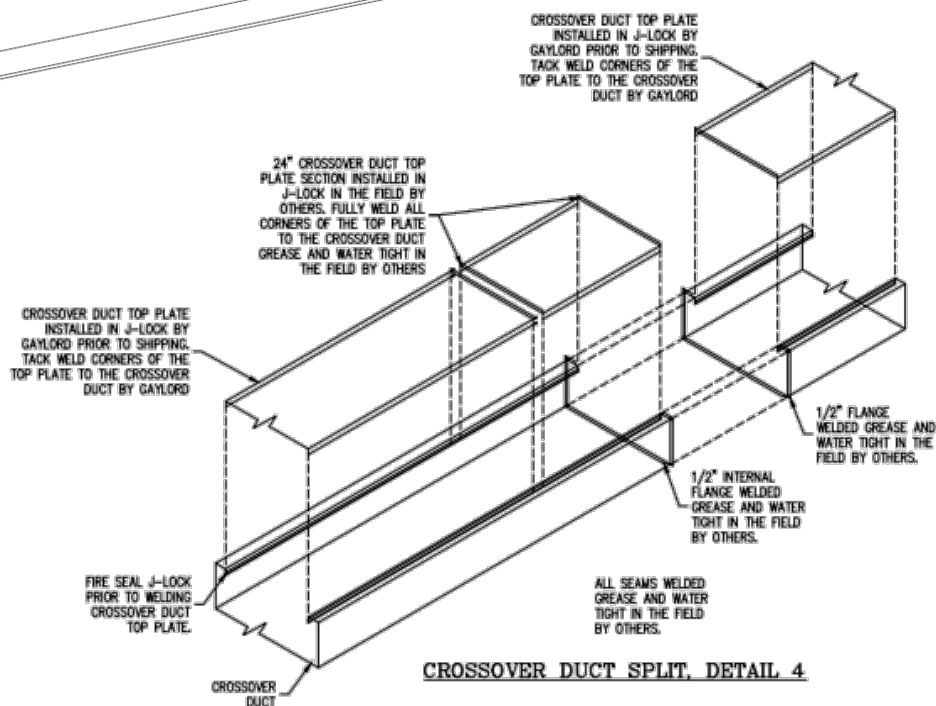

Figure A-2-3 Crossover Duct

Ductwork (Unlisted)

Grease exhaust ducts must be installed in compliance with NFPA-96, IMC and other applicable codes. Use the following guidelines when installing the exhaust ducts:

1. Exhaust ducts must be constructed of 16-gauge steel or 18 gauge stainless steel.
2. Exhaust ducts must be constructed with **continuous external welds and be grease and water tight**.
3. Exhaust duct must be continuously welded to the ventilator duct collar.
4. All elbows should be sweeping 90's. Right angle turns or elbows less than sweeping may negatively impact the performance of the ventilator.
5. All horizontal ducts should slope towards the ventilator and/or towards an approved sump. Amount of slope must be in accordance with the IMC.

Ductwork (Listed)

Follow Manufacturer requirements.

Electrical

Refer to the wiring diagrams on the Gaylord Submittal Drawings for specific wiring interconnections.

1. Provide a 120-volt 20-amp service to the Gaylord Command Center. Optional Voltage 220-volt 50/60 Hz.
2. Wire the Command Center to the designated flex conduit at one end of the ventilator in accordance with the electrical diagram.
3. Wire the Command Center to the exhaust and supply fan(s).
4. If the ventilator is built in multiple sections, and if they contain electric dampers, or thermostats, reconnect the flex conduit provided at the section breaks. The electrical contractor is responsible for making these connections.
5. If the ventilator is provided with light fixtures, provide a separate 120-volt lighting circuit to one of the light J-box on the top of the ventilator. Ventilator may be equipped with built-in light switch.
6. Ventilators built in multiple sections have a flex conduit at the section breaks for interconnecting the light fixture J-boxes. The electrical contractor is responsible for making these connections.

Additional Electrical for Ventilators with a UV System

Refer to the wiring diagrams on the Gaylord Submittal Drawings for specific wiring interconnections.

1. The UV Lamp Modules are shipped with the ventilator. They are installed and tested by a Gaylord Certified Representative at the time of initial Start Up and Demonstration. They must be stored in a clean, dry environment where they will not be damaged by lift trucks, falling objects, etc.
2. Provide 208–250 VAC, 50/60HZ, Single Phase, 20AMP service to the marked j-box on the top of each ventilator section to power the UV Lamp Modules.
3. Ventilators built in no more than two sections shall have a listed flex conduit to interconnect the two UV Ballast Boxes. The electrical contractor is responsible for making this reconnection.

Plumbing (Refer to Figure A-5-1)

Refer to the plumbing diagrams on the Gaylord Submittal Drawings for specific plumbing sizes, and plumbing interconnections.

1. Provide a hot supply to the Wash Control Cabinet. Note: water temperature requirements 140° F. Min. to 180° Max., water pressure requirements 40 psi Min. to 80 psi Max.
2. Plumb one 1.00" line from the Wash Control Cabinet to the three-branch solenoid manifold connection points on top of each ventilator section.
3. Run a drain line from the ventilator drain stub out to a floor sink, or direct connect, as specified. Some ventilators built in multiple sections the drains may interconnect. The plumbing contractor is responsible for making these connections.

Plumbing continued

4. Run a drain line from the drain stub out on the bottom of the Wash Control Cabinet to a floor sink, or direct connect, as specified.
5. Plumb ½ inch PEX or other approved line from the Catalyst injection pump to each Eliminator section.
6. When equipped, plumb ½ inch approved line from the cold-water mist stub on the catalyst injection cabinet to each ventilator section utilizing a cold-water mist manifold.

Airflow Rates

The exhaust air flow rate (and supply if part of the ventilator) must be set at the rate stamped on the ventilator nameplate. The exhaust volumes (and supply when provided) were established under controlled laboratory conditions and greater exhaust and/or lesser supply may be required for complete grease, smoke and vapor removal in specific situations.

Fire Extinguishing System

NFPA-96 requires a Fire Extinguishing System in all ventilators that cover cooking equipment producing grease laden vapors. In many cases the Fire Extinguishing System is pre-piped by Gaylord Industries in the factory with completion of the system by a local Fire System contractor. If not pre-piped, then the entire system would be installed by a local Fire System contractor. Use the following guidelines:

1. Fire Extinguishing System furnished must be in accordance with the terms of its listing and the applicable NFPA or IFC codes and standards.
2. Caution: Fire extinguishing system piping installed on the ventilator at jobsite should be coordinated with Gaylord Industries to ensure piping does not interfere with the ventilator's operation and performance. Improper installation may void Listings of the ventilator.
3. IMPORTANT NOTE: NFPA-96 requires that all gas cooking equipment, and electric cooking equipment that is protected by a Surface Fire Extinguishing System must automatically shut off upon activation of the system.
4. Most building departments require a separate Fire Extinguishing System permit from any other general building or ventilator permit. Installing contractor to check with local building departments for their requirements, and to obtain necessary permits.

Start Up Overview

As one of the benefits of purchasing a Gaylord ELXC SPC Series ventilator is a complete Start-Up Inspection is performed by a Gaylord Authorized Representative or a Gaylord Certified Service Agency. These tests must be conducted prior to use by the operator. Typically, at the time the Start-Up Inspection is performed, the operation and general maintenance of the Gaylord Industries equipment is demonstrated and described to the operating personnel. It is the responsibility of the Gaylord Authorized Representative or Agency to coordinate the date of Start-Up with any personnel such as the GC, owner, owner's rep, Fire Marshall, fire protection contractor, air balancer etc., required to witness the Start-Up.

For the ELXC SPC Series ventilator the Authorized Representative or Agency uses the form titled ventilator Start-Up Inspection Report. This report shall be provided once the startup operations are complete confirming the system is verified and ready to operation

Prestart-Up Requirements

Before a Gaylord Start-Up can be performed, the KEC or contractor responsible must have the ventilator installed and operating. The following is a check list of items that must be completed prior to scheduling a factory Start-Up.

Pre-Startup Check List

- Ventilator is installed above cooking equipment as per Gaylord Submittal Drawings.
- The exhaust ductwork is connected to the ventilator and the exhaust fan.
- The supply ductwork is connected to the ceiling diffusers and the make-up air fan (system).
- The exhaust fan is operational and is running in the correct direction.
- The make-up air system is operational.
- All required electrical connections between the Gaylord Command Center and the ventilator, Building Management Systems, Remote Monitoring Systems, and Fire Extinguishing Systems are completed per plans, and are operational.
- Ventilators built in multiple sections are inter-wired.
- The ventilator lights are wired and operational.
- Hot water supply is connected to the Wash Control Cabinet.
- Hot water lines from the Wash Control Cabinet to the ventilator(s) are connected and operational.
- Ventilators built in multiple sections the hot water interconnections between sections are complete.
- All drain(s) are plumbed to the floor sink or other drain.
- Fire Extinguishing System installed and certified.

- All Gaylord XGS Extractors are installed in the ventilator(s).
- There is a 208–250 VAC, 50/60HZ, Single Phase, 20AMP circuit going to the Ballast Box on the top of each individual ventilator section. One 20-amp power source will serve a two-section ventilator.
- If the ventilator is built in two sections, the interconnection of the two UV Ballast Boxes is complete.
- UV Modules and ESP Cells are received and installed in the ventilators with access doors closed and secure.
- All airflows are confirmed at -0%/+10% of design as specified on Gaylord Industries Approved Project drawings.
- Makeup air inlets, plenum boxes, doorways and pass through windows conform with the Gaylord Capture Guarantee as specified on the Gaylord approved project submittal drawings and contained within this manual.



FIRE DEPARTMENT
9 METROTECH CENTER BROOKLYN, N.Y. 11201-3857

CERTIFICATE OF APPROVAL # 5767
THIS CERTIFICATE IS REVOCABLE, NOT TRANSFERABLE
AND EXPIRES ON January 23, 2021

January 24, 2018

Mr. Russell Robison
Product Development Engineer
Gaylord Industries
10900 SW Avery St
Tualatin, OR 97062

F.P. Index#: 1710036 B-E

FPIMS#: 37301777

By order of Fire Commissioner Daniel A. Nigro, and pursuant to FC112 of the New York City Fire Code, the following equipment or material is accepted for use provided the conditions as outlined below are in full compliance.

Manufacturer: Gaylord Industries 10900 SW Avery St. Tualatin, OR
Product: Prefabricated Commercial Kitchen Hoods
Model Number: ELXC-SPC Series
Pertinent Code Prescribed Tests: § 112-01(b)(1)(D) and § 901.4.5 of New York City Fire Code
UL 710-2012 Ed.6
Laboratory: Intertek Testing Services NA Inc
Report: Intertek Report #102817119CRT-005 issued 6-16-2017
Description: All ELXC-SPC Series hoods are to be installed in wall or island cooking configurations that are for the removal of grease-laden vapors from cooking equipment. Fire damper models shall not be permitted for use in New York City.

This Certificate of Approval (COA) is conditionally issued upon our review of the independent nationally recognized laboratory testing reports and the actual test records for the prefabricated Commercial Kitchen Hoods certifying that the above referenced products have been evaluated and tested for performance in accordance with the UL710 standard for use in approved locations within the City of New York (NYC).
[Note:] Please be advised that Fire Department jurisdiction is solely limited to the materials of construction of the above referenced hoods as it relates to fire hazards that may be found within the exhaust duct system.

CONDITIONS OF APPROVAL:

COA #5767 for Gaylord Industries' ELXC-SPC Series Hoods that are for the removal of grease-laden vapors from commercial cooking equipment as listed in Intertek Report #102817119CRT-005 issued 6-16-2017

January 24, 2018

EXPIRES ON January 23, 2021

Page 2 of 3

1. The installation and use shall comply with all applicable requirements of the New York City Fire Code, Construction Codes, rules and regulations.
2. Intertek and manufacturer's installation, maintenance procedures and safety limitations shall be complied with. Further, the installation shall be in accordance with requirements of UL standard 710.
3. The above referenced ELXC-SPC series hoods will incorporate **only NYC Fire Department approved grease filters** which are to be removed and cleaned weekly or more frequently if necessary, by qualified employees of the restaurant owner or by a cleaning agency. A record of such inspection and cleaning shall be kept on the premises for inspection. The entire exhaust system shall be inspected at least once every three months.
4. Power supply and wiring for controls and luminaries shall comply with the requirements of New York City Electrical Code.
5. The fire extinguishing system shall be suitable for the above referenced hood, grease filter and cooking equipment and subject to the Range Hood Inspection Unit's approval.
6. The Fire Department reserves the right to make periodic inspections of the above referenced products without warning to ensure that maintenance requirements are being followed. These audit inspections will be solely at the discretion of the Fire Department.
7. The above referenced hood unit with filter shall be inspected, cleaned and replaced if necessary, by qualified person hold Certificate of Fitness type W-64 or F-64. A record of such inspection and cleaning shall be kept on the premises for inspection.
8. The Fire Department's conditions of approval shall be enumerated in the installation manuals and sales brochures that will be provided to New York City buyers, users and installers.
9. The Certificate of Approval is issued upon condition that the equipment's technology does not violate any patent, trade name / secret or other intellectual right. Products shall be Intertek listed and product manufacturer shall retain the follow up service program with Intertek Testing Services NA Inc.
10. The Fire Department Certificate of Approval does not constitute an endorsement or recommendation of your product by the Fire Department, but is a certification that your product, as represented, meets the standards as of the date of issuance.
11. All installations shall be subject to inspection by representatives of the Bureau of Fire Prevention which may result in added requirements being imposed.
12. The Fire Department reserves the right to withdraw this approval at any time in the event there is a reasonable doubt that the product does not operate or perform as required by code, the conditions of this resolution or as represented in your application.

COA #5767 for Gaylord Industries'ELXC-SPC Series Hoods that are for the removal of grease-laden vapors from commercial cooking equipment.as listed in Intertek Report #102817119CRT-005 issued 6-16-2017

January 24, 2018

EXPIRES ON January 23, 2021

Page 3 of 3

13. This Certificate of Approval does not grant the right to use any trademark associated with the New York City Fire Department (the letters FDNY, the FDNY Shield design, the FDNY Maltese Cross design and the seal of the City of New York). The unauthorized use of trademarks in connection with the sale of commercial goods or services violates federal and state laws.
14. The manufacturer and/or the local sales representative of the manufacturer/applicant, the restaurant owner/manager shall notify the Fire Department - Technology Management Unit, of any explosion, fire, reportable smoke condition, or other release of hazardous material, or other emergency related to the above referenced product(s) within seven days of the incident. Such report shall be **faxed to (718) 999-0091** and also notify us as soon as possible after transmitting the fax with a follow-up phone call **(718) 999-2391** and email to confirm our receipt of that incident report.

Any change in company name or ownership, product name, material of construction, product design, or model number of any product included on this certificate must be immediately reported to this Department in writing.

Very truly yours,



Anthony Hsueh
Senior Project Manager
Technology Management

AH / 5767Y17/8.doc



THE CITY OF NEW YORK
DEPARTMENT OF ENVIRONMENTAL PROTECTION
Bureau of Environmental Compliance
59-17 Junction Boulevard, 9th Floor, Flushing, New York 11373
Records Control (718) 595-3855

Commercial Char Broilers 09/2017

COMMERCIAL CHAR BROILER CERTIFICATION

A SUMMARY OF TEST RESULTS SHALL BE SUBMITTED ALONG WITH THIS CERTIFICATION FORM

Manufacturer Name: Gaylord Industries		Manufacturer Representative Name & Title: Russell Robison / Director of Research and Development	
Address: 10900 SW Avery St.		Email: russ.robison@gaylordventilation.com	
City / Town / Borough: Tualatin	State: OR	Zip: 97062	Manufacturer's Website: www.gaylordventilation.com
			Phone: (503) 691-2010

COMMERCIAL CHAR BROILER EMISSIONS CONTROL DEVICE DESCRIPTION

BRAND NAME: Gaylord Industries

TRADE NAME: Gaylord Eliminator

MODEL NUMBER: ELXC-SPC Series

ANY ACCESSORIES INSTALLED TO ENHANCE OR SUPPORT THE OPERATION OF THE EMISSIONS CONTROL DEVICE: _____

(OPTIONAL - Not needed) MERV 16 w/ Single Pass Activated Carbon & Potassium Permanganate Blend

MAXIMUM AIR FLOW RATE: 2000 CFM/ Section. Hoods Optionally Made up of Multiple Sections.

EMISSIONS CONTROL DEVICE USED: ESP Cell

ASTM METHOD USED: ASTM F1695-03 - Cooking procedure administered by the University of California at Riverside

EPA METHOD USED: Method 5 - Administered by NELAC Member 3rd party contractor.

I hereby certified that testing of this commercial char broiler has been conducted in accordance with the requirements set forth in Section 24-149.4 of the Administrative Code of the City of New York and 15 RCNY Sections 37-02 and 37-06.

SIGNATURE 	PRINT NAME Russell Robison / Director of Research and Development	DATE 28-Dec-2017
--	--	---------------------

FOR DEPARTMENT USE ONLY		
Certification #:	<u>CB2018-0002</u>	REMARKS:
REVIEWER'S USE ONLY		
Review Date: <u>1/16/2018</u>	ID & Initials: <u>RHWAughn 1486301</u>	Issuance Date: <u>1/17/2018</u>

FOR INFORMATION, QUESTIONS, AND INQUIRIES: Please visit our website at www.nyc.gov/dep or call 311

THE GAYLORD VENTILATOR LIMITED WARRANTY FOR MODEL ELXC SPC SERIES

July 2017

The Gaylord Ventilator and component parts furnished with The Gaylord Ventilator are warranted to be free from defects of material and workmanship under normal use when installed, operated and serviced in accordance with factory recommendation. Rubber and synthetic rubber parts such as "O" rings, diaphragms, poppet checks, and gaskets are perishable when caustic cleaning solutions are used and, therefore, are not covered by this warranty.

The Manufacturer's obligation under this warranty and any warranties implied by law shall be limited to repairing or replacing at its option any part of said equipment when either Gaylord Industries, Inc. or the Licensed Gaylord Manufacturer's examination shall disclose to its satisfaction to be thus defective, for a period of one (1) year from the date of beneficial use, or eighteen months from date of shipment, whichever occurs first, provided proper and acceptable evidence of such is recorded at the factory.

Note GAYLORD INDUSTRIES AND THE LICENSED GAYLORD MANUFACTURER SHALL NOT BE RESPONSIBLE FOR INCIDENTAL OR CONSEQUENTIAL DAMAGES RESULTING FROM A BREACH OF THIS WARRANTY.

In the United States, the labor required to make repairs and replacements under this warranty shall be furnished by Gaylord Industries or the Licensed Gaylord Manufacturer or its authorized representative. Such labor shall only be provided Mondays through Fridays during standard work hours, at straight time rates. Requests for repairs or replacement parts should be made to GAYLORD INDUSTRIES, 10900 SW Avery Street, Tualatin, Oregon 97062.

Outside the United States, all replacement parts furnished under this warranty shall be F.O.B. Gaylord Industries, Tualatin, Oregon U.S.A. The owner shall pay the necessary freight delivery charges, and necessary labor for removal and installation of parts, and any tariffs, duties or taxes.

Component parts not manufactured by Gaylord Industries, such as electrical switches, solenoid coils, relays, etc., shall be warranted under the terms and conditions of the warranty published by the manufacturer of said component parts.

This warranty does not cover routine maintenance such as detergent replacement and inspection of the cleaning system and UV system as spelled out in The Gaylord Ventilator Technical Manual. This warranty also does not cover malfunctions or improper operation caused by inadequate hot water, low water pressure, fluctuating electrical power or power surges, waste stoppages, and improper exhaust fan operation and/or a lack of proper maintenance.

This is the sole warranty with respect to the aforesaid items. NEITHER GAYLORD INDUSTRIES OR THE GAYLORD LICENSED MANUFACTURER OR ANY OTHER PARTY MAKES ANY OTHER WARRANTY OF ANY KIND WHATSOEVER, EXPRESSED OR IMPLIED, AND ALL IMPLIED WARRANTIES OF MERCHANTABILITY AND FITNESS FOR A PARTICULAR PURPOSE WHICH EXCEED THE AFORESAID OBLIGATIONS ARE HEREBY DISCLAIMED AND EXCLUDED FROM THIS AGREEMENT.

Service and Warranty Policies

1. No warranty work shall be performed on the product without a PO from Gaylord Industries, if financial reimbursement to be requested.
2. No warranty shall be provided on equipment that has been started up and in operation for more than 90 days unless, a product maintenance schedule has been created and performed per the requirements of this technical manual.
3. Any, and all, wearable parts are not to be considered warranty items, regardless of installation date, unless previously authorized by the factory.



**WORLDWIDE SALES, MANUFACTURING AND SERVICE
FOR THE NAME AND LOCATION OF THE NEAREST
CERTIFIED SERVICE AGENCY, VISIT OUR WEB SITE:**

WWW.GAYLORDVENTILATION.COM

OR CONTACT US AT:

GAYLORD INDUSTRIES

10900 SW AVERY STREET
TUALATIN, OREGON 97062 U.S.A

Phone: 503-691-2010

1-800-547-9696

Fax: 503-692-6048

email: info@gaylordventilation.com

LOCAL SERVICE AGENCY

© Copyright 2020 Gaylord Industries